

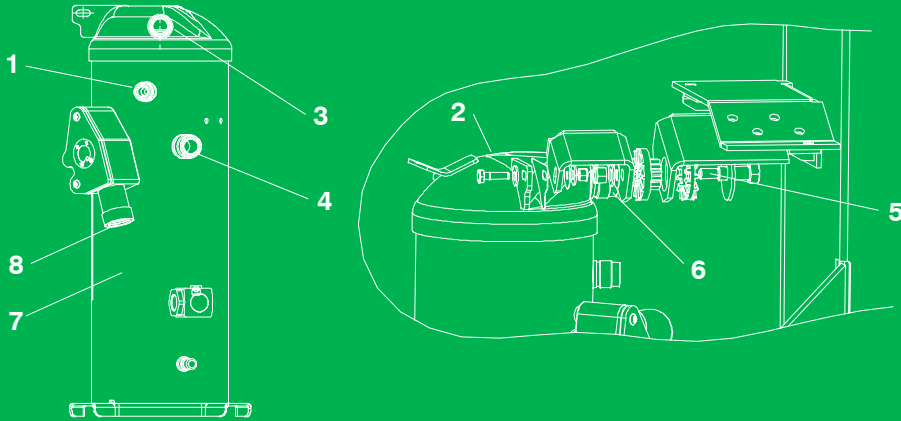

Container Refrigeration

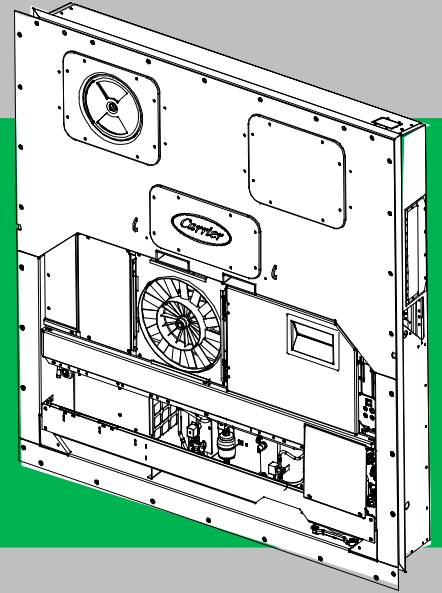

SERVICE PARTS LIST for 69NT40-551-400 to 425 Container Refrigeration Units



TRANSICOLD

**SERVICE PARTS LIST
CONTAINER REFRIGERATION UNIT**

**MODEL
69NT40-551-400 to 425**

TABLE OF CONTENTS

1	QUICK LIST - CLAMPS, FILTER-DRIER, FUSE, TY-WRAPPS, WIRE TERMINALS	1
2	REFRIGERATION UNIT ASSEMBLY	2
2.1	REFRIGERATION UNIT - AREA LOCATOR	2
2.2	RAIN GUTTERS	4
2.3	HANDLES	4
2.4	THERMOMETER PORT	5
2.5	CONTROL BOX DOOR - LCD AND LED DISPLAYS	6
2.6	CONTROL BOX	8
2.7	CONTROL BOX - STD ELECTRICAL COMPONENTS, RM, CFS, EBS	10
2.8	CONTROL BOX - CONTROLLER MODULE AND SOFTWARE CARDS	12
2.9	CONTROL BOX - DISPLAY MODULE AND COMMUNICATIONS INTERFACE MODULE	14
2.10	CONDENSER FAN MOTOR AND COIL	16
2.11	CONDENSER FAN GRILLE ASSEMBLY	18
2.12	COMPRESSOR TUBING	20
2.13	RECEIVER	22
2.14	WATER-COOLED CONDENSER	23
2.15	ECONOMIZER, EXAPANSION VALVE, SOLENOID VALVE ANDFILTER DRIER	24
2.16	SRS AND STS	26
2.17	EVAPORATOR FAN ASSEMBLY	27
2.18	UPPER FRESH AIR MAKE-UP AND ACCESS PANEL	28
2.19	LOWER FRESH AIR MAKE-UP VENT	30
2.20	EVAPORATOR COIL - REAR PANELS REMOVED	32
2.21	USDA	34
2.22	BACK PANEL ASSEMBLY - OPTION 1 - ALUMINUM BOLTED	36
2.23	OPTION 7 AND OPTION 8 - ELECTRONIC PARTLOW TEMPERATURE RECORDER	38
2.24	COMPRESSOR MOUNTING COMPONENTS AND GUARD	40
2.25	TRANSDUCERS	44
2.26	CABLE RESTRAINT COMPONENTS	45
2.27	VOLTAGE CABLES	46
2.28	AUTOTRANSFORMER KIT	48
2.29	LABELS AND DECALS (Not Applicable to All Units)	50
3	INTERROGATOR AND ACCESSORIES	52
3.1	DATAVIEW/DATAREADER	52
3.2	INTERROGATOR RECEPTACLE	54
4	COMPRESSOR	56
5	CONTROLLER/DATACORDER CONFIGURATION	57
6	TOOLS	58

INTRODUCTION

1 INTRODUCTION

The Carrier Transicold model 69NT40-551 series units are of lightweight aluminum frame construction, designed to fit in the front of a container and serve as the container front wall.

2 CONFIGURATION IDENTIFICATION

Unit identification information is provided on a plate located near the compressor. The plate provides the unit model number, the unit serial number and the unit parts identification number (PID). The model number identifies the overall unit configuration while the PID provides information on specific optional equipment, factory provision to allow for field installation of optional equipment and differences in detailed parts.

Configuration identification for the models covered herein is provided in the Carrier Transicold Container Unit Matrix at www.transcentral.carrier.com.

3 OPTION DESCRIPTIONS

Various options may be factory or field fitted to the base unit. These options are listed in the tables and described in the following subparagraphs.

3.1 Battery

The refrigeration controller may be fitted with standard replaceable batteries or rechargeable battery pack.

3.2 Dehumidification

The unit may be fitted with a humidity sensor. This sensor allows setting of a humidity set point in the controller. In the dehumidification mode the controller will operate to reduce internal container moisture level.

3.3 Control Box

The control box is composite material and may be fitted with a lockable door.

3.4 Temperature Readout

The unit may be fitted with suction and discharge temperature sensors. The sensor readings may be viewed on the controller display.

3.5 Pressure Readout

The unit is fitted with standard suction and discharge transducers. The transducer readings may be viewed on the controller display.

3.6 USDA

The unit may be supplied with fittings for additional temperature probes which allow recording of USDA Cold Treatment data by the integral DataCORDER function of the Micro-Link refrigeration controller.

3.7 Interrogator

Units that use the DataCORDER function are fitted with interrogator receptacles for connection of equipment to download the recorded data. Two receptacles may be fitted, one accessible from the front of the container and the other mounted inside the container (with the USDA receptacles).

3.8 Remote Monitoring

The unit may be fitted with a remote monitoring receptacle. This item allows connection of remote indicators for COOL, DEFROST and IN RANGE. Unless otherwise indicated, the receptacle is mounted at the control box location.

3.9 Communications

The unit may be fitted with a communications interface module. The communications interface module is a slave module which allows communication with a master central monitoring station. The module will respond to communication and return information over the main power line. Refer to the ship master system technical manual for further information.

3.10 Compressor

The unit is fitted with a scroll compressor with either standard piping (equipped with suction, discharge, economizer and oil return service valves) or with semi-hermetic piping (equipped with suction, discharge and economizer service connections).

3.11 Condenser Coil

The unit is fitted with a 4 row coil using 7mm tubing.

3.12 Autotransformer

An autotransformer may be provided to allow operation on 190/230, 3 phase, 50/60 hertz power. The autotransformer raises the supply voltage to the nominal 380/460 volt power required by the base unit. The autotransformer may also be fitted with an individual circuit breaker for the 230 volt power.

If the unit is fitted with an autotransformer and communications module, the autotransformer will be fitted with a transformer bridge unit (TBU) to assist in communications.

3.13 Temperature Recorder

The unit may be fitted with an electronic recorder manufactured by Partlow Corporation.

3.14 Gutters

Rain gutters may be fitted over the control box and recorder section to divert rain away from the controls. The different gutters include standard length bolted gutters, extended length gutters and riveted gutters.

3.15 Handles

The unit may be fitted with handles to facilitate access to stacked containers. These handles include fixed handles (located at the sides of the unit) and/or a hinged handle at the center (attached to the condenser coil cover).

3.16 Thermometer Port

The unit may be fitted with ports in the front of the frame for insertion of a thermometer to measure supply and/or return air temperature. If fitted, the port(s) will require a cap and chain.

3.17 Water Cooling

The refrigeration system may be fitted with a water cooled condenser. The condenser is constructed using copper-nickel tube for sea water applications. The water cooled condenser is in series with the air cooled condenser replaces the standard unit receiver. When operating on the water cooled condenser, the condenser fan is deactivated by either a water pressure switch or condenser fan switch.

3.18 Back Panels

Back panel designs that may be fitted include panels of aluminum and stainless steel. Panels may be fitted with access doors and/or hinge mounting.

3.19 460 Volt Cable

Various power cable and plug designs are available for the main 460 volt supply. The plug options tailor the cables to each customers requirements.

3.20 230 Volt Cable

Units equipped with an autotransformer require an additional power cable for connection to the 230 volt source. Various power cable and plug designs are available. The plug options tailor the cables to each customers requirements.

3.21 Cable Restraint

Various designs are available for storage of the power cables. These options are variations of the compressor section front cover.

3.22 Upper Air (Fresh Air Make Up)

The unit may be fitted with an upper fresh air makeup assembly. The openings may also be fitted with screens.

3.23 Lower Air (Fresh Air Make Up)

The unit may be fitted with a lower fresh air makeup assembly. These assemblies are supplied in two designs, the standard design and the macro design. The openings may also be fitted with screens.

3.24 Evaporator

The unit is fitted with an evaporator coil and a hermetic thermal expansion valve.

3.25 Evaporator Fan Operation

The units are fitted with normal evaporator fan operation. Opening of an evaporator fan internal protector will shut down the unit.

3.26 Labels

Operating Instruction and Function Code listing labels will differ depending on the options installed. For example, additional operating instructions are required to describe start-up of a unit equipped with an autotransformer. Labels available with additional languages are listed in the parts list.

3.27 Plate Set

Each unit is equipped with a tethered set of wiring schematic and wiring diagram plates. The plate sets are ordered using a seven digit base part number and a two digit dash number. **(See Unit Matrix)**

3.28 Controller

Two different controllers are available:

1. Remanufactured - Controller is the equivalent of a new OEM controller and is supplied with a 12 month warranty.

2. Repaired - Controller has had previous faults repaired and upgraded with the latest software.

Note: Repaired controllers are NOT to be used for warranty repairs only full OEM Remanufactured controllers are to be used.

Controllers will be factory equipped with the latest version of operational software, but will NOT be configured for a specific model number and will need to be configured at the time of installation or sale.

3.29 Stepper Drive

All the units covered by this manual have suction modulating valves which act to control system capacity. Units indicated as being fitted with "stepper drive" have digital control motors fitted to the suction modulating valve to open and close the valve in steps as required.

3.30 Condenser Grille

Two styles of condenser grilles are available: direct bolted grilles and hinged grilles.

OPTION LEGEND

General	
-	Feature Not Applicable
X	Features that apply to model
P	Factory Installation of Equipment to Allow Field Installation
AutoTransformer Codes	
1	Transformer Fitted
2	Transformer With CB2 Fitted
3	Transformer With CB2 and Transformer Bridging Unit
4	Transformer With CB2 and Receptacle
Back Panel Codes	
1	Bolted Panels
Battery Codes	
S	Standard (Disposable) Cells
R	Rechargeable Cells
1	Rechargeable Cells - Secure Location
Cable Guard Codes	
1	Standard Cable with Receiver
2	Standard Cable with Full Guard
3	Transicord Cable with Full Guard
4	Transicord Cable without Receiver
5	Standard Cable with Receiver, Orange
Cable Restraint Codes	
2	Left Bungy Cord Only
3	J-Hook
R	Dummy Receptacle
Communications Codes	
2	High Data Rate
4	Low Data Rate
Compressor Codes	
S	Scroll
SS	Scroll with Semi-Hermetic Piping
Condenser Grille Codes	
B	Bolted Grille
H	Hinged Grille
Condenser Codes	
4	Four Row Coil

Control Box Codes	
C	Composite Box Without Door Lock
CL	Composite Box With Door Lock
Control Box Door	
1	LCD Display
2	LED Display
Emergency Bypass Codes	
B	Emergency Bypass & Emergency Defrost
EB	Emergency Bypass Only
Gutter Codes	
1	Standard Length Bolted Gutters
3	Extended Length Gutters
4	Rivieted Gutters
Handle Codes	
2	Two Side
Interrogator Receptacle Codes	
1	Left Straight Mount
3	Box Mount
4	Left Mount
5	Left Angled Mount
Label Codes	
1	English
2	English / Spanish
5	English / Traditional Chinese
Lower Air Codes	
1	No Lower Fresh Air
2	Lower Fresh Air Installed
3	Lower Fresh Air With Screen Installed
4	Lower Fresh Air Installed With VPS
Pressure Readout Codes	
T	Factory Installed Pressure Transducers
Temperature Recorder Codes	
7	Standard Electronic Partlow
8	Special Electronic Parlow
9	No Temperature Recorder
10	Electronic Partlow (Both)

Thermometer Port Codes	
1	Supply Air Port
2	Return Air Port
B	Both Ports
Upper Air Codes	
1	No Upper Fresh Air
2	Upper Fresh Air Installed
3	Upper Fresh Air Installed With Screen
4	Upper Fresh Air Installed With VPS
USDA Codes	
D	Option D
V	Option V
1	Option 1
2	Option 2

230 and 460 Volt Cable Codes	
1	Option 1
2	Option 2
3	Option 3
4	Option 4
5	Option 5
6	Option 6
7	Option 7
8	Option 8
9	Option 9
Water Cooling Codes	
W	Water Pressure Switch
F	Condenser Fan Switch

4 ORDERING INSTRUCTIONS

All orders and inquiries for parts must include: Parts Identification Number (**PID**), Model Number, Unit Serial Number, Part Number, Description of part as shown on list and Quantity required. Address all correspondence for parts to the following address:

CARRIER TRANSICOLD DIVISION
 Replacement Components Group, TR-20
 P.O. Box 4805, Syracuse, New York 13221
 or FAX to: (315) 432-3778

5 LETTER DESIGNATIONS

The following letter designations are used to classify parts throughout this list:

- A/R = *As Required*
- N/A = *Not Available*
- NS = *Not shown in illustration*
- NSS = *Not sold separately* - Order next higher assembly or kit.
- PID = *Parts Identification Number* - essential to identify unit configuration.
- PL = *Purchase Locally*
- SST = *Stainless Steel* - 300 Series unless otherwise specified.
- SV = *Suffix SV* - added to part number designates service replacement part.

1 QUICK LIST - CLAMPS, FILTER-DRIER, FUSE, TY-WRAPS, WIRE TERMINALS	
PART NO.	DESCRIPTION
34-00373-51	Clamp, Tube, 1/4 - SST
34-00373-53	Clamp, Tube, 3/8 - SST
34-00373-05	Clamp, Tube, 1/2 - SST
34-00373-07	Clamp, Tube, 5/8 - SST
34-00373-59	Clamp, Tube, 3/4 - SST
34-00373-11	Clamp, Tube, 7/8 - SST
34-00373-65	Clamp, Tube, 1-1/8 - SST
34-00373-88	Clamp, Tube, 1-1/4 - SST
34-00373-69	Clamp, Tube, 1-3/8 - SST
34-00373-71	Clamp, Tube, 1-1/2 - SST
22-00066-01	Connector, Butt End, Wire Range - 22 to 16 AWG
22-00066-02	Connector, Butt End, Wire Range - 16 to 14 AWG
22-00066-03	Connector, Butt End, Wire Range - 12 to 10 AWG
22-00041-00	Connector, Closed End, Wire Range - 22 to 14 AWG
22-00041-02	Connector, Closed End, Wire Range - 18 to 10 AWG
14-00311-02SV	Filter-Drier
22-02336-02	Fuse, 5 Amp (F1 & F2)
22-02336-04	Fuse, 10 Amp (FEB)
22-02336-08	Fuse, 7.5 Amp (F3A & F3B)
22-01140-01	Ring Terminal, #6, Wire Range - 12 to 10 AWG
22-01140-02	Ring Terminal, #10, Wire Range - 12 to 10 AWG
22-01140-04	Ring Terminal, 3/8, Wire Range - 12 to 10 AWG
22-00119-04	Ring Terminal, 1/4, Wire Range - 12 to 10 AWG
22-00120-04	Ring Terminal, #10, Wire Range - 16 to 14 AWG
22-00120-07	Ring Terminal, 5/16, Wire Range - 16 to 14 AWG
22-00121-07	Ring Terminal, #10, Wire Range - 22 to 16 AWG
22-01139-04	Ring Terminal, 3/8, Wire Range - 16 to 14 AWG
22-01141-01	Spade Terminal, 1/4 X 5/16, Wire Range - 16 to 14 AWG
22-00595-01	Spade Terminal, 3/8, Wire Range - 12 to 10 AWG
22-01106-00	Spiral Wrap, 1/4 Diameter X 25 Feet Long
22-01107-00	Spiral Wrap, 1/2 Diameter X 25 Feet Long
66U1-3803	Tube, Heat Shrink, 1/4 ID X 2-1/8 Long
66U1-3803-1	Tube, Heat Shrink, 1/2 ID X 2-3/4 Long
44-01043-05	Ty-Wraps, 5-1/2 Inches Long
44-01043-07	Ty-Wraps, 11.00 Inches Long
22-50007 Series	Wire Markers
07-00345-00	Sealant, Pipe (Used to seal fittings on unit with R-134a)
07-00313-00	Cleaner, Coil
74-50137-00	Paint, One Coat, 1 Compressor
74-50137-01	Paint, One Coat, 20 Compressors
74-50137-10	Paint, Two Coats, 1 Compressor
74-50137-11	Paint, Two Coats, 20 Compressors

2 REFRIGERATION UNIT ASSEMBLY

2.1 REFRIGERATION UNIT - AREA LOCATOR

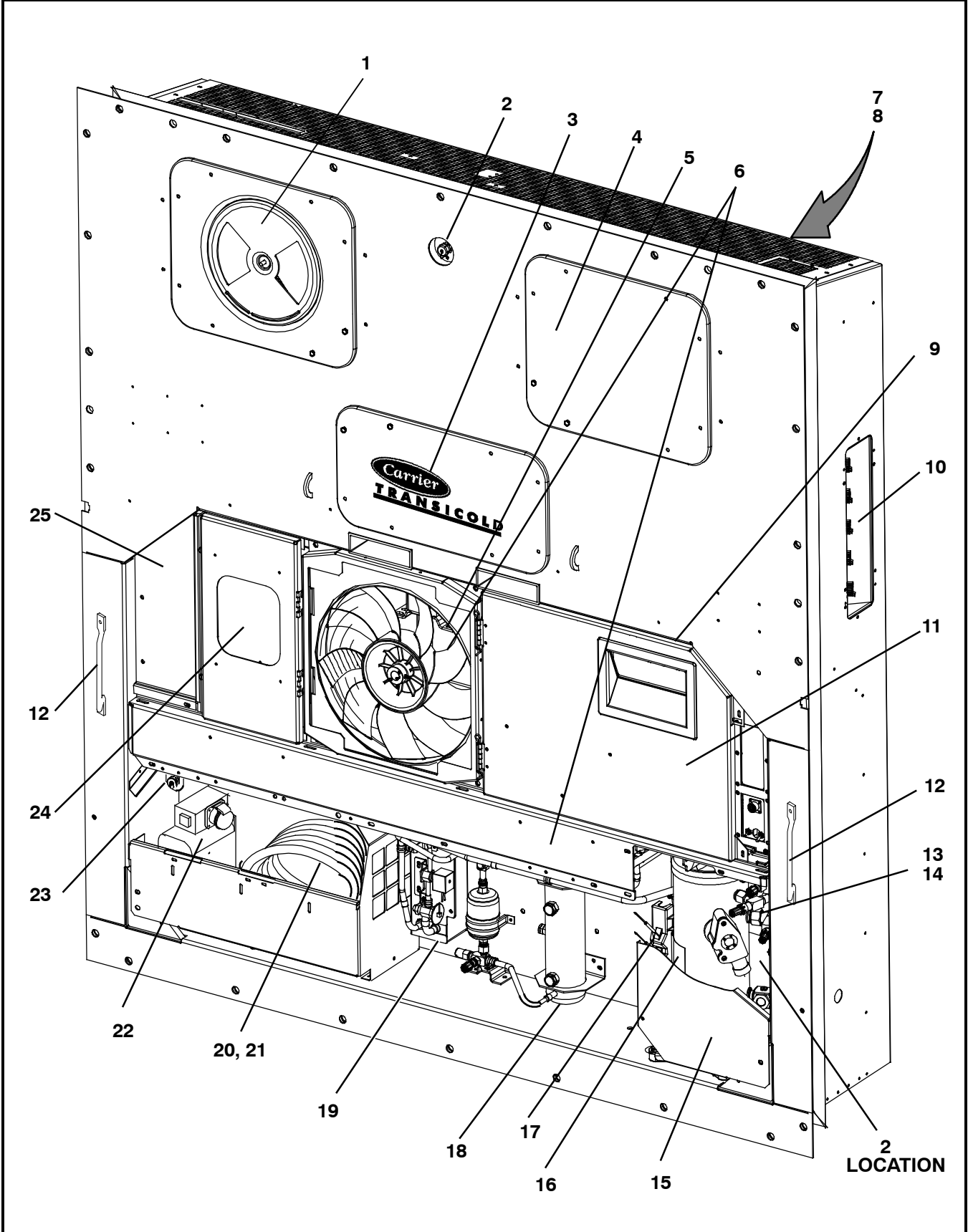

2.1 REFRIGERATION UNIT - AREA LOCATOR (Continued)		
Item	Section Number	Area Description
1	Refer to Section 2.18	Upper Fresh Air Makeup and Access Panels
2	Refer to Section 2.4	Thermometer Port
3	Refer to Section 2.29	Labels and Decals
4	Refer to Section 2.17	Evaporator Fan Assembly
5	Refer to Section 2.11	Condenser Fan Grille Assembly
6	Refer to Section 2.10	Condenser Fan Motor and Coil
7	Refer to Section 2.19	Evaporator Coil
8	Refer to Section 2.21	Back Panels
9	Refer to Section 2.2	Rain Gutters
10	Refer to Section 2.20	USDA
11	Refer to Section 2.9	Control Box
12	Refer to Section 2.3	Handles
13	Refer to Section 2.11	Compressor Tubing
14	Refer to Section 2.24	Transducers
15	Refer to Section 2.24	Compressor Guard
16	Refer to Sections 2.24 or 4	Compressor
17	Refer to Section 2.15	Sensors - SRS & STS
18	Refer to Section 2.13 or 2.14	Receiver or Water-Cooled Condenser
19	Refer to Section 2.14	Economizer and Filter Drier
20	Refer to Section 2.27	Power Cable
21	Refer to Section 2.27	Power Plug
22	Refer to Section 2.28	Autotransformer
23	Refer to Section 3	Interrogator and Accessories
24	Refer to Section 2.23	Temperature Recorder
25	Refer to Section 2.19	Lower Fresh Air Makeup

2.2 RAIN GUTTERS

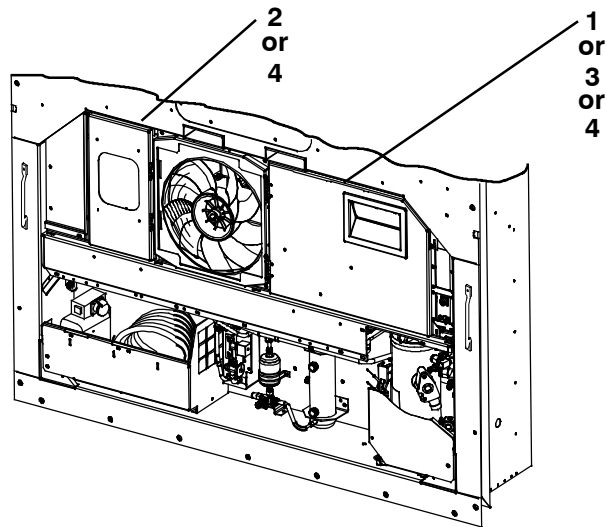

Item	Part Number	Description	Qty
OPTION 1 - STANDARD LENGTH - BOLTED			
1	69NT35-3987	Gutter, Rain (Bolted, Standard - Right Side)	1
2	69NT35-3997-1	Gutter, Rain (Bolted, Standard & Extended Length - Left Side)	1
OPTION 3 - EXTENDED LENGTH - BOLTED			
2	69NT35-3997-1	Gutter, Rain (Bolted, Standard & Extended Length - Left Side)	1
3	69NT35-8548	Gutter, Rain (Bolted - Right Side)	1
OPTION 4 - RIVETED			
4	68-12417-00	Gutter, Rain (Riveted - Right and Left Side)	2

2.3 HANDLES

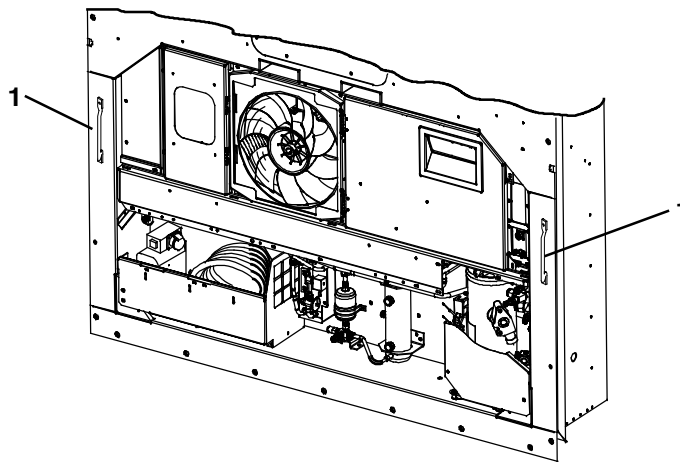

Item	Part Number	Description	Qty
OPTION 2 - TWO SIDE			
1	69NT35-8113	Handle, Fixed	2

2.4 THERMOMETER PORT

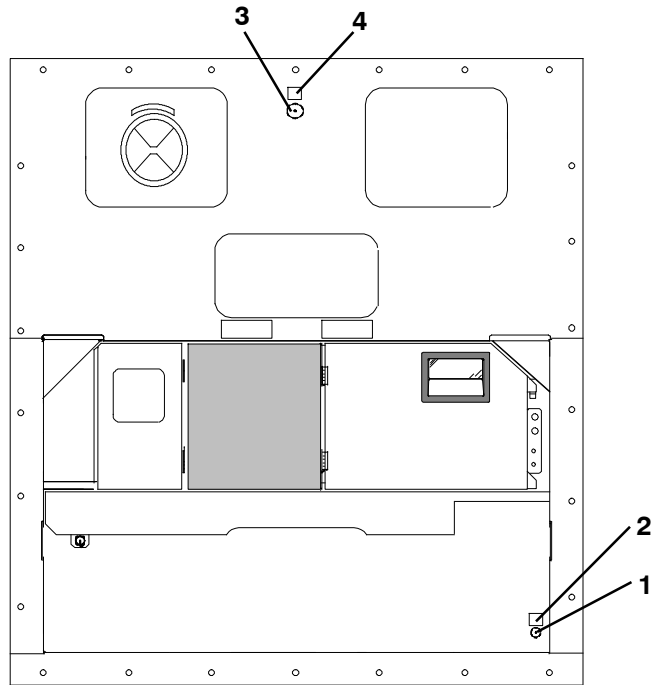

Item	Part Number	Description	Qty
OPTION 1 - SUPPLY AIR PORT			
1	66U1-8662	Cap & Chain Assembly	1
2	62-10557-00	Label	1
OPTION 2 - RETURN AIR PORT			
3	66U1-8662	Cap & Chain Assembly	1
4	62-10557-00	Label	1
OPTION B - SUPPLY AND RETURN PORTS			
1 & 3	66U1-8662	Cap & Chain Assembly	2
2 & 4	62-10557-00	Label	2

2.5 CONTROL BOX DOOR - LCD AND LED DISPLAYS

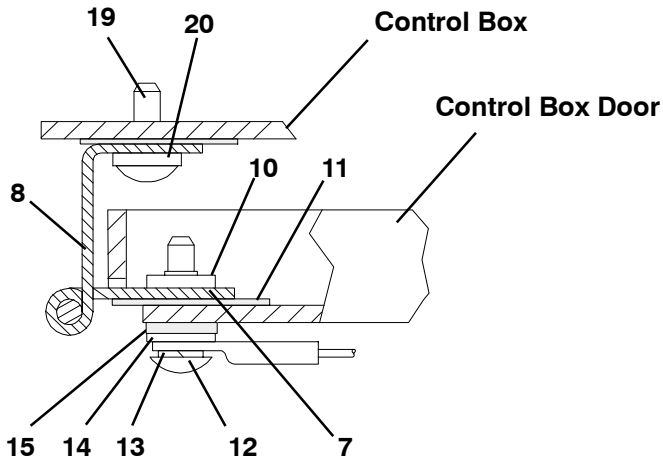
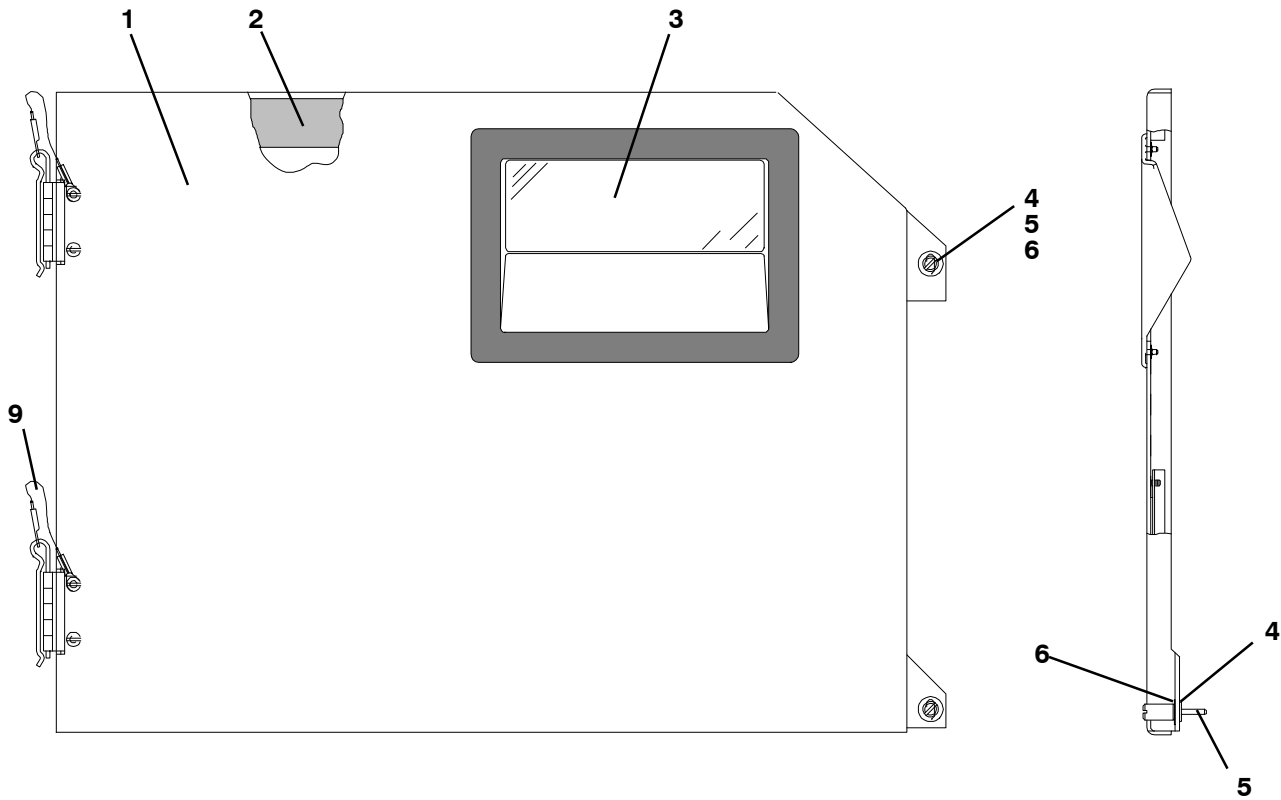

HINGE ASSEMBLY - SECTIONAL VIEW

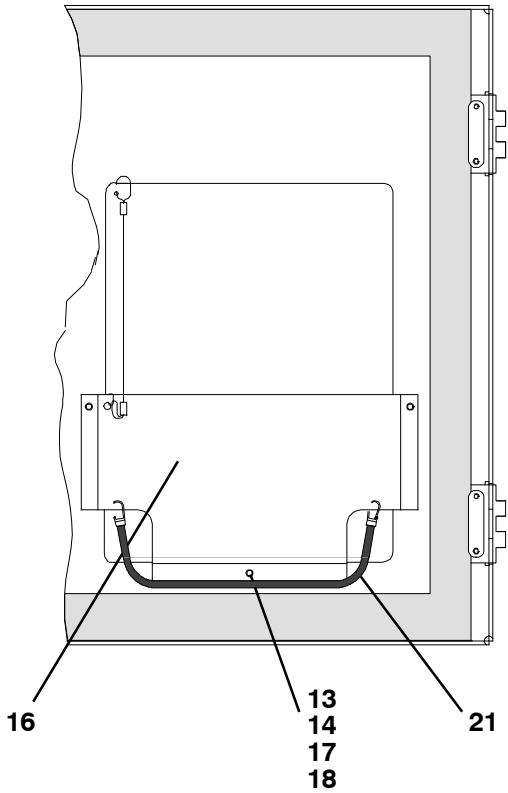

DOOR ASSEMBLY - PARTIAL BACK VIEW

2.5 CONTROL BOX DOOR - LCD AND LED DISPLAYS (Continued)			
Item	Part Number	Description	Qty
OPTION 1 - LCD DISPLAY			
1	69NT42-688-10	Door Assembly, LCD Display, Includes:	1
2	42-00270-02	Gasket, Door	1
3	58-04366-00SV	Window and Gasket Assembly, Control Box Door - Lexan	1
4	34-06169-00	Washer, Retaining - SST	2
5	66U1-6811-8	Screw, Retaining, Panel, 0.300-0.625 - SST	2
	66U1-6811-15	Screw, Retaining, Wing, 0.300-0.625 - SST	2
6	34-06053-00	Washer, Mylar, 0.250 ID X 0.800 OD	4
7	44-00300-01	Hinge, Half	1
8	44-00300-02	Hinge, Half	1
9	44-00300-03	Pin Assembly, with Tether	1
10	34-01167-01	Retainer, Nut	2
11	58-04101-00	Protector, Mylar (Hinge)	2
12	66U1-2403-1	Screw, Truss Head, #10-24 X 3/4 Long - SST	4
13	66U1-5331-3	Washer, Lock, #10 - SST	7
14	66U1-5321-8	Washer, Flat, #10 - SST	7
15	34-06053-05	Washer, Mylar, 0.205 ID X 0.600 OD	4
16	68-13577-00	Pocket, Placard	1
17	34-00665-09	Locknut, HXHD, #10-24 - SST	3
18	34-06107-00	Rivet, Blind, 1/8 Diameter, Grip Range - 0.188-0.250	3
19	66U1-5371-7	Screw, #10-24 X 1/2 Long - SST	4
20	66U1-5321-8	Washer, Flat, #10 - SST	4
21	58-04346-00	Door Strap Kit	1
OPTION 2 - LED DISPLAY			
1	79-01911-00	Door Assembly, LED Display, Includes:	1
2	42-00270-02	Gasket, Door	1
3	69NT35-5022-6	Window	1
	42-00611-00	Foam, Double Coated	1
4	34-06169-00	Washer, Retaining - SST	2
5	66U1-6811-8	Screw, Retaining, Panel, 0.300-0.625 - SST	2
	66U1-6811-15	Screw, Retaining, Wing, 0.300-0.625 - SST	2
7	44-00300-01	Hinge, Half	1
8	44-00300-02	Hinge, Half	1
9	44-00300-03	Pin Assembly, with Tether	1
10	34-01167-01	Retainer, Nut	2
12	66U1-2403-1	Screw, Truss Head, #10-24 X 3/4 Long - SST	4
13	34-00663-09	Washer, Lock, #10 - SST	4
14	66U1-5321-8	Washer, Flat, #10 - SST	4
15	34-06053-05	Washer, Mylar, 0.205 ID X 0.600 OD	4
16	68-13577-00	Pocket, Placard	1
17	34-00795-09	Locknut, HXHD, #10-24 - SST	6
18	34-06107-00	Rivet, Blind, 1/8 Diameter, Grip Range - 0.188-0.250	3
20	66U1-5321-8	Washer, Flat, #10 - SST	4

2.6 CONTROL BOX

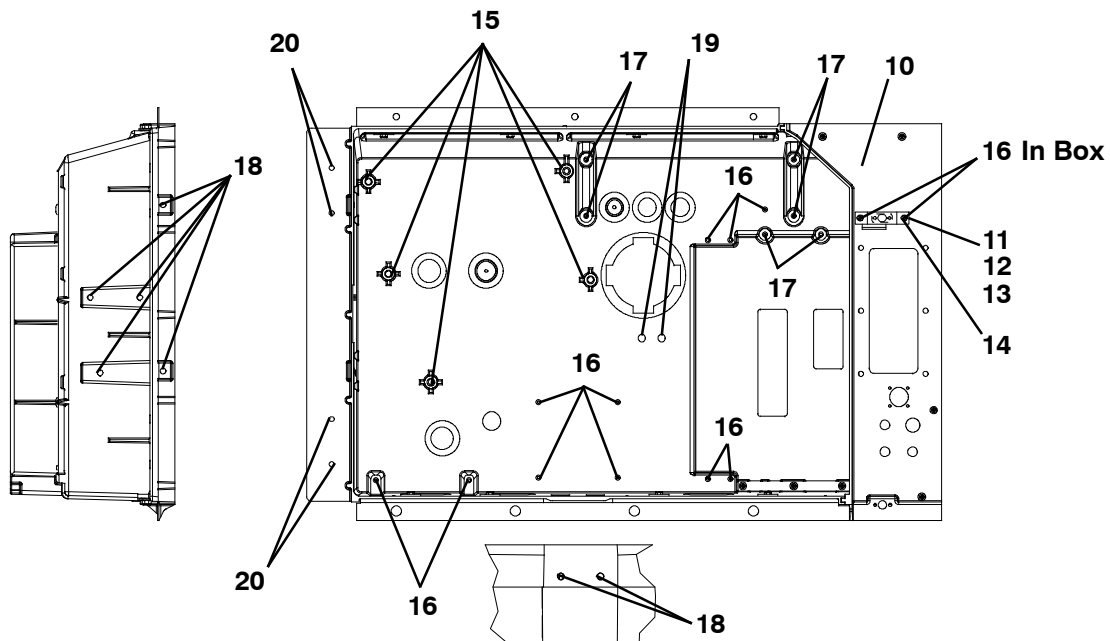
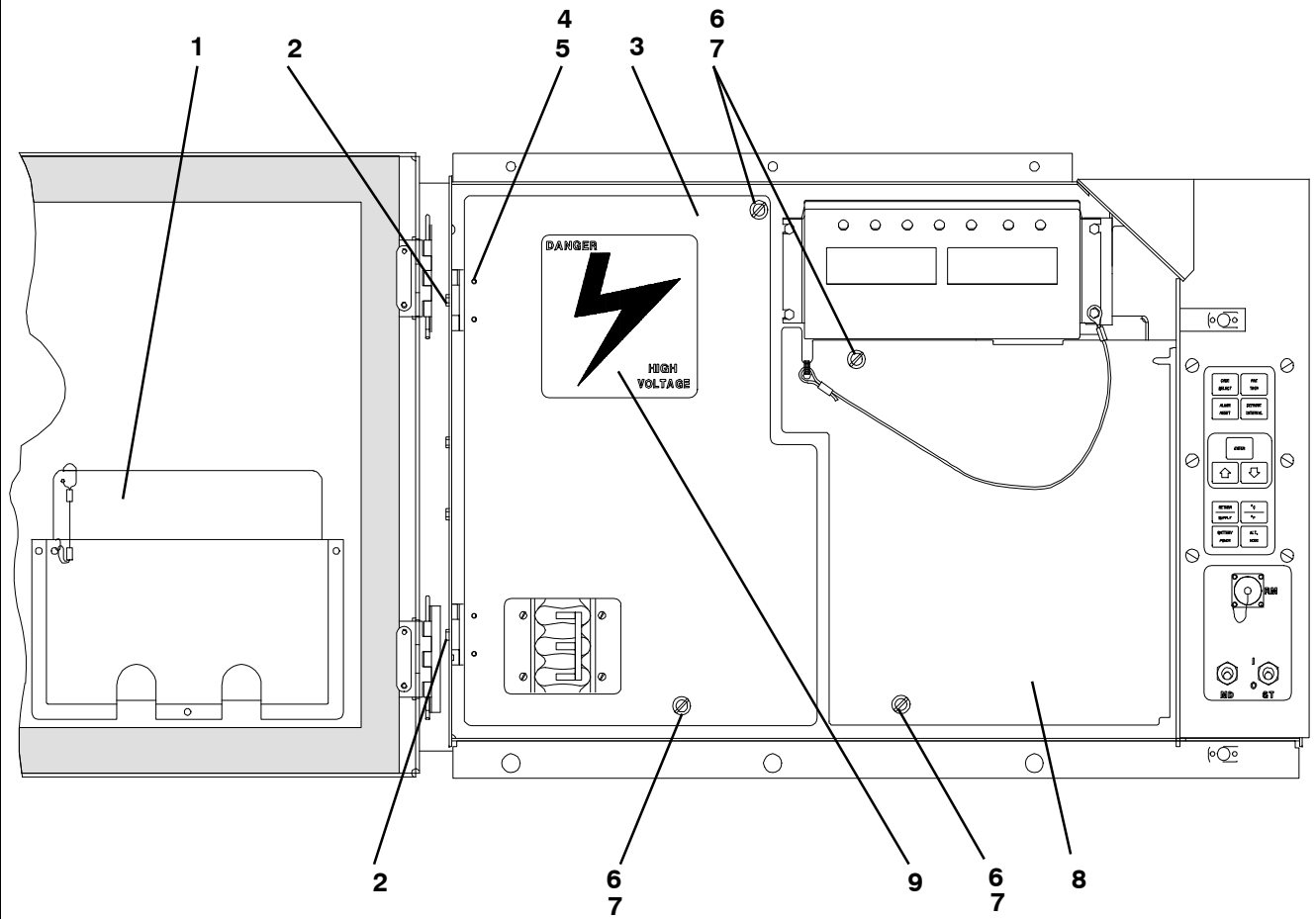

OPTION C & CL - COMPOSITE BOX

2.6 CONTROL BOX (Continued)			
Item	Part Number	Description	Qty
1	-	Plate, Schematic & Diagram (Refer to Container Unit Matrix)	1
2	66U1-2403	Screw, Truss Head, #10-24 X 1/2 Long - SST	2
3	69NT43-125-1	Shield, High Voltage (Plastic) - Includes:	1
4	44-00343-00	Hinge	2
5	34-00928-02	Rivet, Blind, 1/8 Diameter, Grip Range - 1/8-3/16 - SST	4
6	34-50015-00	Stud & Retainer Package - Includes:	4
NS	NSS	Stud, Fastener	1
NS	NSS	Retainer, Fastener Stud	1
7	34-06139-03	Fastener	4
8	69NT43-124-5	Shield, Low Voltage (Lexan) - With Tether	1
9	62-03957-01	Label, Danger-High Voltage	1
10	58-04668-00	Control Box, Standard Composite	1
11	69NT35-6272	Bracket, Non-Locking, White	1
	69NT35-6272-1	Bracket, Non-Locking, Orange	1
	69NT35-2287	Bracket, Locking (See Note 1)	1
12	34-01142-01	Receptacle, Retaining	1
13	34-00928-01	Rivet, Blind, 1/8 Diameter, Grip Range - 1/16 - 1/8	2
	34-00928-02	Rivet, Blind, 1/8 Diameter, Grip Range - 1/18 - 3/16 (See Note 2)	2
14	66U1-2403	Screw, Truss Head, #10-24 X 1/2 Long - SST	2
NS	76-00724-00SV	Crack, Chip and Hole Repair Kit	1
NS	76-50084-00SV	Insert Repair Kit - Includes:	1
15	34-06231-01	Insert - 17.53 X 9.91 mm (0.690 X 0.390 in) 1/4-20 Threads - NSS	10
16	34-06231-03	Insert - 15.88 X 6.35 mm (0.625 X 0.250 in) 10-24 Threads - NSS	10
17	34-06231-04	Insert - 25.15 X 7.54 mm (0.990 X 0.297 in) 10-24 Threads - NSS	10
18	34-06231-05	Insert - 10.16 X 9.53 mm (0.400 X 0.375 in) 10-24 Threads - NSS	10
19	34-06231-06	Insert - 12.70 X 9.91 mm (0.500 X 0.390 in) 1/4-20 Threads - NSS	10
20	34-06231-07	Insert - 9.53 X 6.76 mm (0.375 X 0.266 in) 10-24Threads - NSS	10
NS	02-00082-00	Durabond Epoxy - NSS	1
NS	07-00390-00	Static Mixing Tube - NSS	1
NS	07-00391-00	Application Gun - Required for Insert Repair	1
NOTES			
1. The bracket is bolted to the control box - order 69NT35-2287 for locking bracket.			
2. When 69NT35-2287 is used, 34-00928-02, rivet, is to be used in the upper door location.			

2.7 CONTROL BOX - SHIELDS REMOVED, STD ELECTRICAL COMPONENTS, RM, CFS, EBS

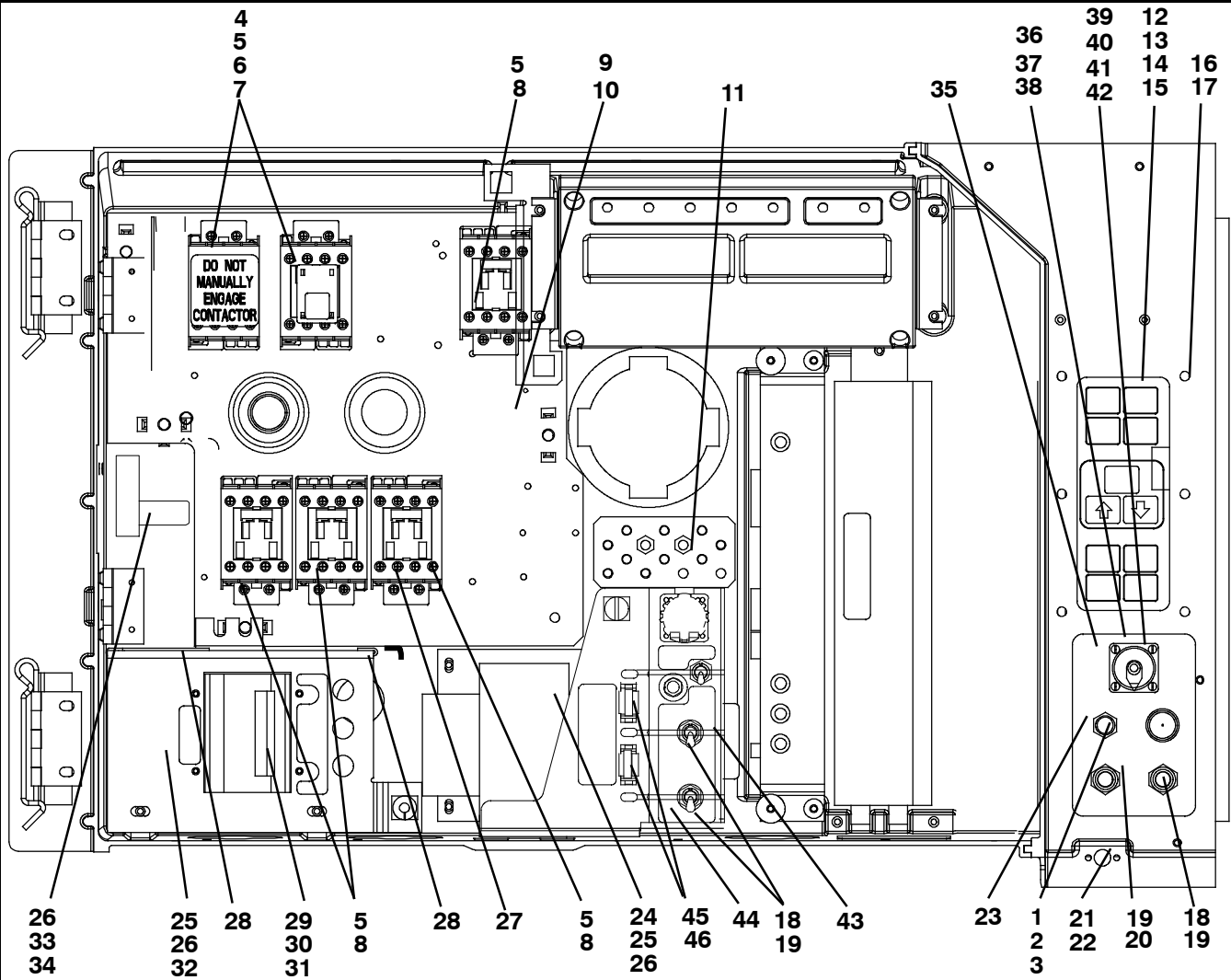

Item	Part Number	Description	Qty
OPTION F - CONDENSER FAN SWITCH			
1	10-00298-01	Switch, Toggle (CFS)	1
2	66U1-9752	Seal, Bushing	1
3	58-04145-06	Plate, Switch (with extra switch location)	1
OPTION 1 - NORMAL EVAPORATOR FAN OPERATION			
See Items 6 and 7 for contactor placement			
4	10-00431-07	Contactor, Compressor (CH) (30 Amp)	2
5	34-06243-00	Screw, HXHD w/ Washer, #8-32 X 5/8 Long - SST	12
6	10-00431-08	Cover, Contactor	2
7	62-11018-00	Label, Contactor	12
8	10-00431-06	Contactors, (CF), (HR) & (EF & ES) (12 Amp)	4
9	68-13427-00SV	Panel, Contactor - Includes:	1
10	34-06224-01	Screw, HXHD, Captive Washer 1/4-20 X 0.62 Long - SST	4
11	69NT41-982-3	Plate, Ground	1
12	79-66669-00	Pad, Key - Includes:	1
13	NSS	Dot, Indicator (Green) - See Note	1
14	NSS	Gasket (Between Key Pad and Key Pad Plate Assembly)	1

Note: If unit is not already fitted with a green indicator dot (Item 13) on the upper right corner of the control box door, install dot as illustrated.

2.7 CONTROL BOX - SHIELDS REMOVED, STANDARD ELECTRICAL COMPONENTS (Continued)

Item	Part Number	Description	Qty
15	NSS	Plate Assembly, Key Pad Mounting	1
16	34-66630-00	Screw, Pan Head, #10-24 X 3/4 Long - SST	6
17	34-06212-10	Washer, Plain, #10	6
18	10-01129-07SV	Switch, Toggle (On-Off)	1
19	66U1-9752	Seal, Bushing	2
20	10-01129-10	Switch, Toggle (MDS) (if equipped)	1
21	34-00928-01	Rivet, Blind, 1/8 Diameter, Grip Range - 1/16 - 1/8	6
22	34-01142-01	Receptacle	1
23	68-14796-00	Plate, Switch	1
24	10-00332-21SV	Transformer, Base Unit	1
25	66U1-5371-7	Screw, HXHD, #10-24 X 1/2 Long - SST	A/R
26	66U1-5321-8	Washer, Flat, #10 - SST	A/R
27	10-00431-02	Contact, Auxiliary	1
28	66CH1-1172-46	Trim, Flexible (85 Feet Long, Cut to Length)	A/R
29	34-00663-07	Washer, Lock, #6 - SST	4
30	66U1-7842-13	Circuit Breaker - 460 vac, 25 Amp (CB1)	1
31	66U1-6651-4	Screw, Pan Head, #6-32 X 3/8 Long - SST	4
32	69NT35-6278	Bracket, Circuit Breaker	1
33	10-00439-01	Transformer, Current Sensing (CS)	1
34	34-06223-00	Screw, Captive Washer, #10-24 X 0.56 Long - SST	2
REMOTE MONITORING (STANDARD LOCATION)			
35	68-14796-03	Plate, Switch, with RM	1
36	34-00848-10	Screw, Round Head, #4-40 X 5/8 Long - SST	4
37	66U1-5321-6	Washer, Flat, 0.125 ID - SST	4
38	34-00667-05	Nut, Self-Locking, #4-40 - SST	4
39	22-02341-00	Receptacle, Remote Monitoring (RM)	1
40	22-02368-00	Plug, Remote Monitoring	1
41	22-02341-01	Cap and Tether, Receptacle Assembly	1
42	66U1-6835	Gasket, Remote Monitoring Receptacle	1
REMOTE MONITORING (OPTIONAL LOCATIONS)			
Refer To Section 3.2			
EMERGENCY BYPASS			
43	66U1-3882-02	Wire Tie	3
44	10-00446-00	Emergency Bypass Module	1
45	22-02336-04	Fuse (10A)	2
46	22-01455-03	Fuse Holder	2

2.8 CONTROL BOX - CONTROLLER MODULE AND SOFTWARE CARDS

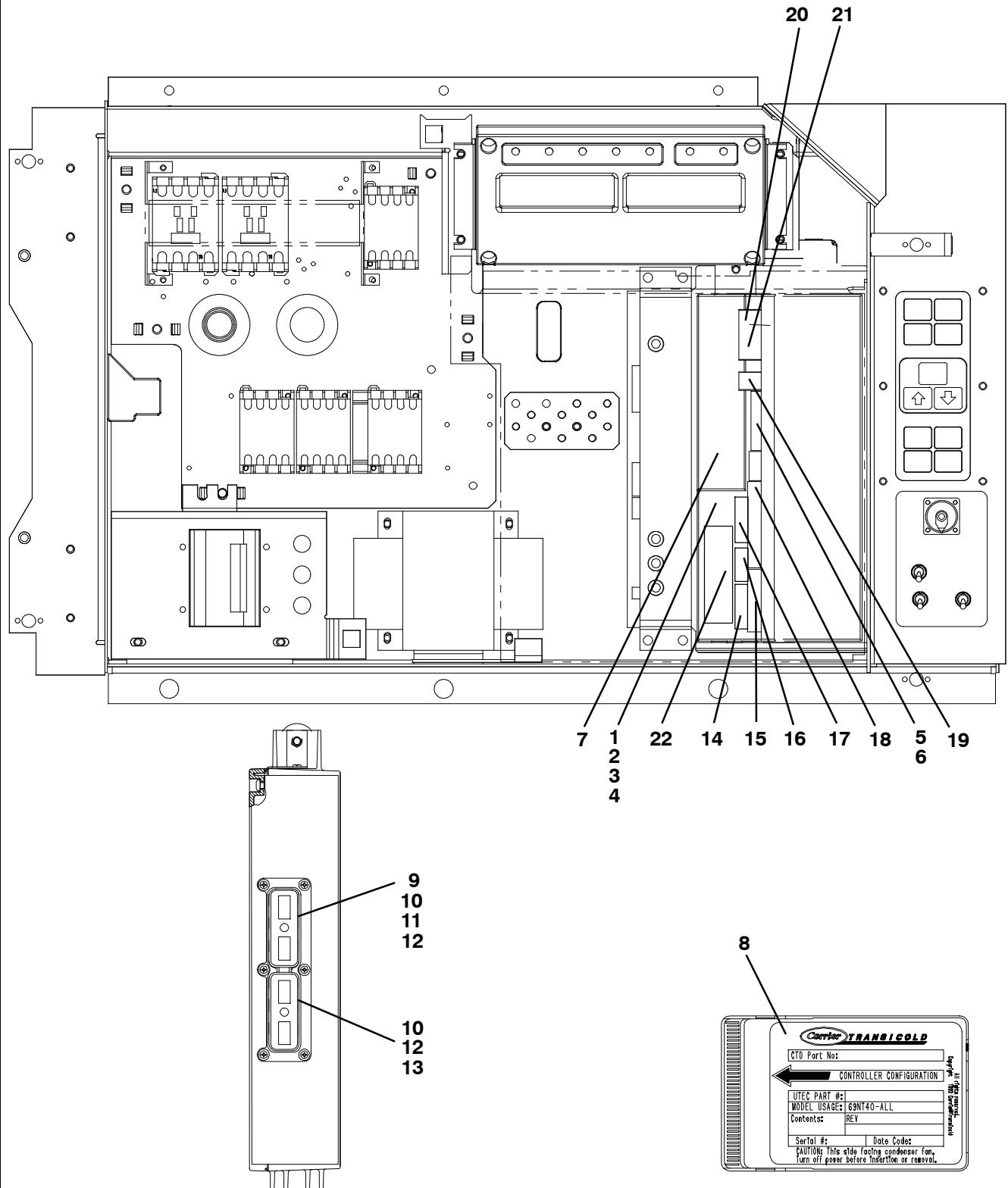

View - Back of Controller/DataCORDER

2.8 CONTROL BOX - CONTROLLER MODULE AND SOFTWARE CARDS (Continued)

Item	Part Number	Description	Qty
1	-	Module, Controller/DataCORDER - Refer to Section 5 - Includes:	-
2	66U1-5371-7	Screw, HXHD, #10-24 X 1/2 Long - SST	1
3	69NT35-2692	Washer, Fender, 0.063 Thick - SST	1
4	58-01184-00	Retainer, Screw, 0.141 ID	1
5	22-02336-08	Fuse, 7.5 Amp (F3A & F3B)	2
6	22-02336-02	Fuse, 5 Amp (F1 & F2)	2
7	62-02719-00	Label, Controller/DataCORDER Port	1
8	12-00594-xx/5315	Card, Controller/DataCORDER Operation Software	1
9	22-01777-00SV	Connector (EC A-K) - 30 Pin	1
10	22-01777-03	Socket, 20 AWG	35
11	22-50100-00	Socket, 18 AWG	4
12	22-01777-04	Plug, Sealing	21
13	22-01777-01SV	Connector (EC L-Y) - 30 Pin	1
14	22-4031-01	Connector (KE) - 5 Pin	1
15	22-01556-01	Connector (KB) - 10 Pin	1
NS	22-01621-23	Connector (KP) - 9 Pin (Connects to Ribbon Cable)	1
16	22-4031-00	Connector (KD) - 4 Pin	1
17	22-4031-02	Connector (KC) - 6 Pin	1
18	22-01556-02	Connector (KA) - 14 Pin	1
19	22-01622-00	Connector (MC) - 8 Pin	1
20	22-01622-01	Connector (MA) - 12 Pin	1
21	22-01622-02	Connector (MB) - 16 Pin	1
NS	09-00369-00SV	Battery, Real Time Clock, (Within the Controller)	1
NS	22-50157-00	Wire Harness, Controller to Current Sensing Transformer)	1
NS	22-01713-06	Wire Harness, Display Module to Controller/DataCORDER Module	1
NS	62-02735-00	Label, Warning, Don't use 12-00327 ! -(Located on the control box behind the Controller/DataCORDER module.)	1
NS	62-02738-08	Label, Warning, 55xx Series - (Located on the high & low voltage shields)	1
NS	62-02738-04	Label, Warning, 55xx Series - (Located on the bottom panel of the control box between the Communications Interface module and the switch panel.)	1
OPTION R - RECHARGEABLE BATTERY OPTION			
22	30-00407-02SV	Controller/DataCORDER Module Rechargeable Battery Pack with Connector	A/R
OPTION S - STANDARD BATTERY OPTION			
22	30-00407-01	Controller/DataCORDER Module Standard Battery Holder with Connector	A/R
OPTION 1 - SECURE RECHARGEABLE BATTERY OPTION			
NOTE	76-50149-00	Controller/DataCORDER Module Rechargeable Battery Pack with Connector	A/R
NOTE			
Refer to technical manual for battery location.			

2.9 CONTROL BOX - DISPLAY MODULE AND COMMUNICATIONS INTERFACE MODULE

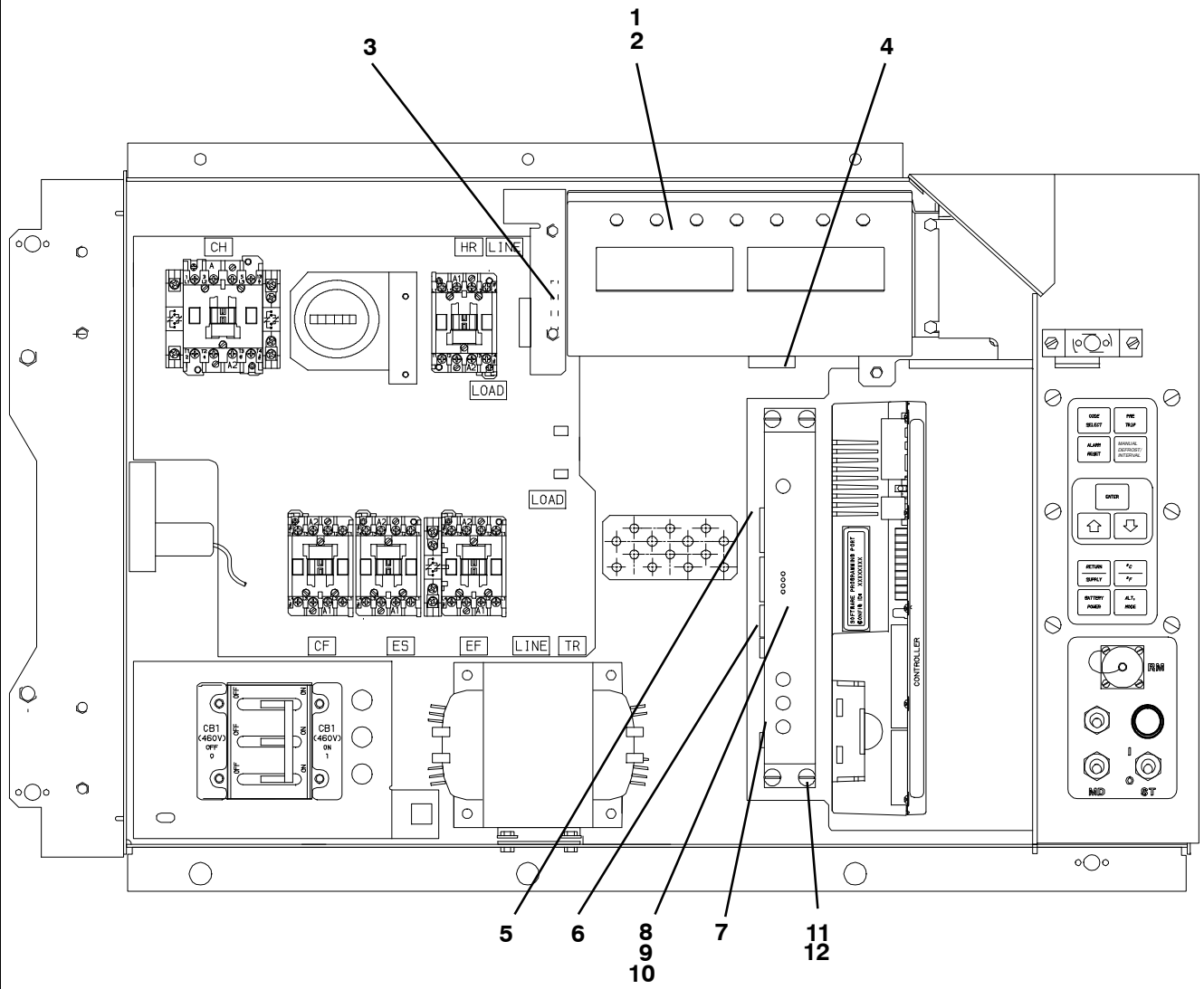

2.9 CONTROL BOX - DISPLAY MODULE AND COMMUNICATIONS INTERFACE MODULE (Continued)

Item	Part Number	Description	Qty
1	12-00433-00RP	Module, LCD Display (Option 1)	1
	12-00433-02 RP	Module, LED Display (Option 2)	1
2	34-06223-01	Screw, HXHD, #10-24 X 1/2 Long - SST	4
3	22-01621-03	Connector (MK) - 9 Pin	1
4	22-01556-06	Connector (MB) - 16 Pin	1
5	22-01556-04	Connector (CIC) - 7 Pin	1
6	22-02396-02	Connector (CIB) - 3 Pin	1
7	22-01556-00	Connector (CIA) - 7 Pin	1
NS	22-01713-02	Wire Harness, Key Pad to Display Module	1
OPTION 2 - COMMUNICATIONS INTERFACE MODULE - HIGH DATA RATE			
8	12-00573-00SV	Module, Communications Interface - Includes:	1
9	66U1-3442-2	Stud, Fastener, 1/4 turn, 0.705 Long - SST	4
10	66U1-9212-1	Retainer, Push-on	4
11	34-06223-00	Screw, Captive Washer #10-24 X 0.56 - SST	2
12	58-01184-01	Retainer, Screw 0.75 OD	2
OPTION 4 - COMMUNICATIONS INTERFACE MODULE - LOW DATA RATE			
8	12-00275-19SV	Module, Communications Interface - Includes:	1
9	66U1-3442-2	Stud, Fastener, 1/4 turn, 0.705 Long - SST	4
10	66U1-9212-1	Retainer, Push-on	4
11	34-06223-00	Screw, Captive Washer #10-24 X 0.56 - SST	4
12	58-01184-00	Retainer, Screw 0.75 OD	4

2.10 CONDENSER FAN MOTOR AND COIL

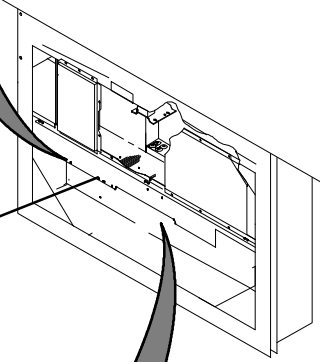
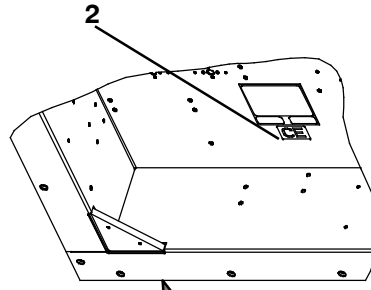
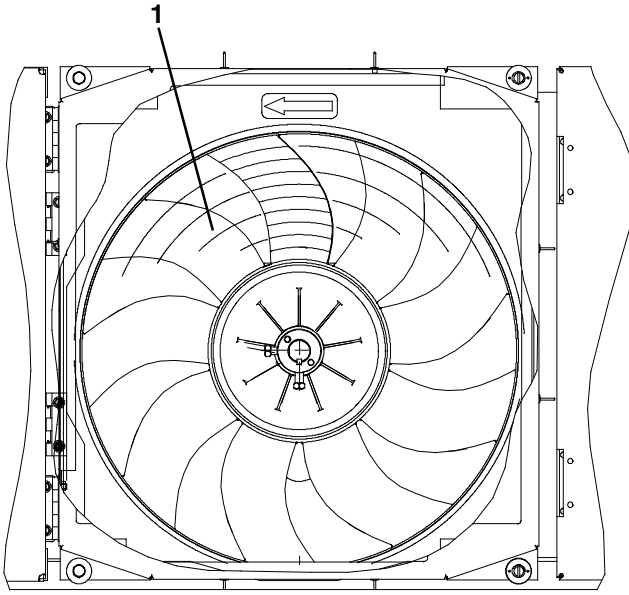

Option 4

- 16
- 17
- 18
- 19
- 20
- 21

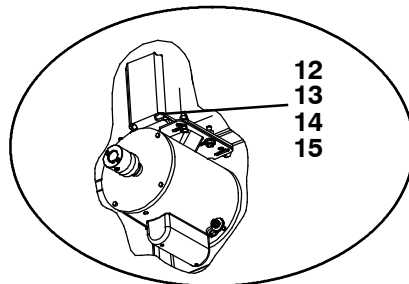
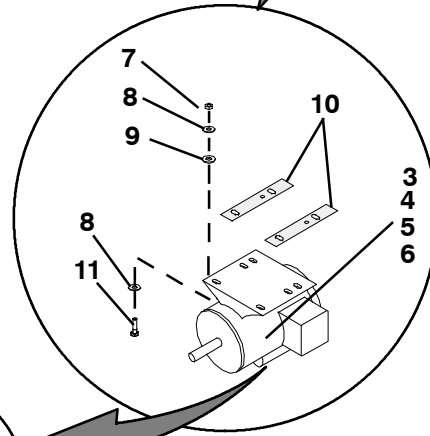

2.10 CONDENSER FAN MOTOR AND COIL (Continued)			
Item	Part Number	Description	Qty
OPTION 4 - FOUR ROW (3/8") CONDENSER COIL			
1	38-00585-00	Fan, Condenser	1
2	62-02785-00	Label, CE	1
3	54-00586-20	Motor, Condenser - Includes:	1
4	04-50029-00	Bearing	2
5	22-01997-05	Pin	A/R
6	22-01997-10	Pin, Grounding	A/R
7	34-00667-12	Nut, Self-Locking, 5/16-18	4
8	34-01181-01	Washer, Flat	8
9	34-06053-02	Washer, 0.375 ID X 1.000 OD	4
10	69NT35-6112	Protector, Condenser Fan Motor Mounting	2
11	66U1-5361	Screw, Cap HXHD, 5/16-18 X 1.25	4
12	69NT35-3452	Shim	1
13	69NT35-3452-1	Shim	1
14	69NT35-3452-2	Shim	1
15	69NT35-3452-3	Shim	1
16	68-13201-01	Cover, Condenser Coil, Blue Includes:	1
	69NT43-148-4	Cover, Condenser Coil, White Includes:	1
17	58-04480-00	Bumper (For Use with Uncoated Center Handles)	A/R
18	58-04481-00	Plug (For Use with Coated Handles or Units with no Center Handle)	A/R
19	81-01855-22SV	Coil, Condenser (Copper), 4-Row - Includes Mylar Washers	1
20	69NT35-8703	Protector (Apply Between Frame and Coil and Coil Cover)	4
21	58-04026-10	Protector, Mylar (Apply Between Coil and Coil Cover, RH and LH Sides)	2

2.11 CONDENSER FAN GRILLE ASSEMBLY

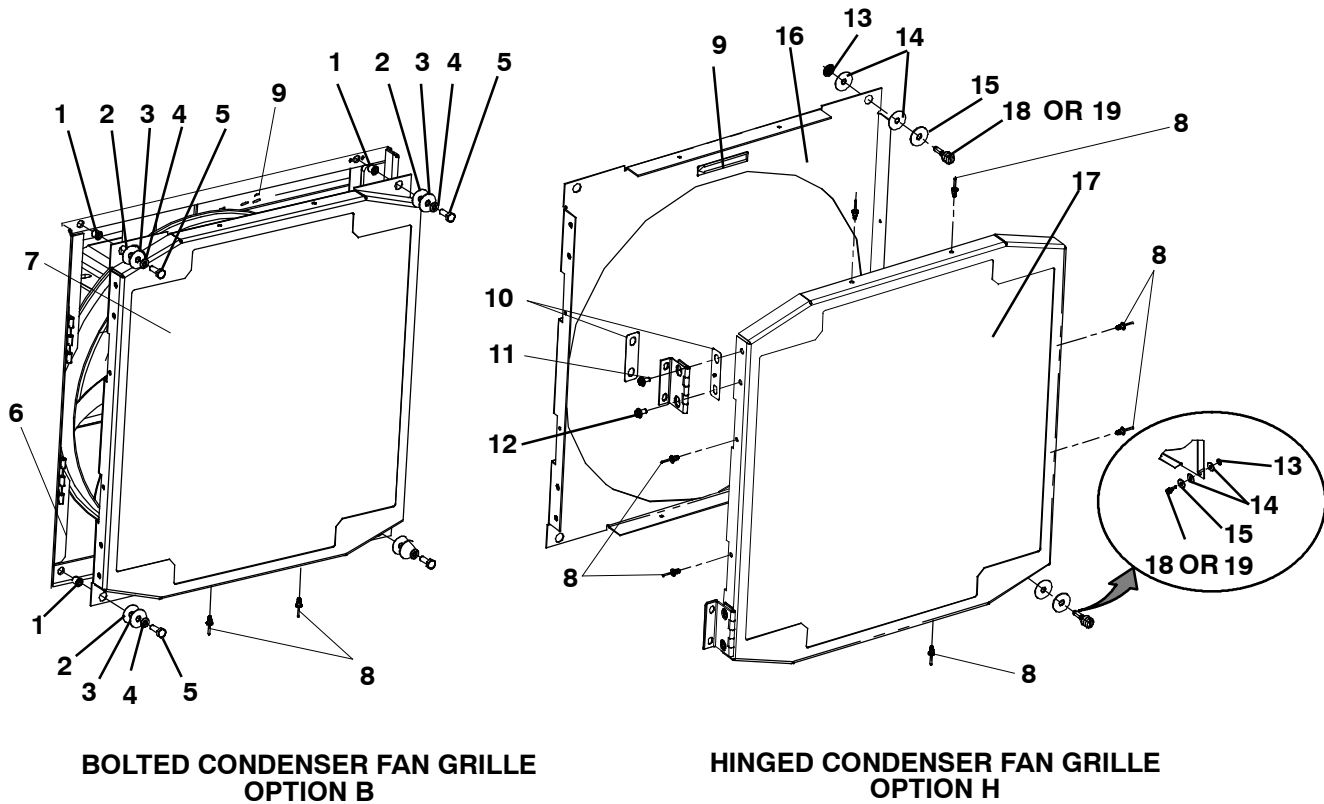

**BOLTED CONDENSER FAN GRILLE
OPTION B**

**HINGED CONDENSER FAN GRILLE
OPTION H**

Item	Part Number	Description	Qty
OPTION B - BOLTED CONDENSER FAN GRILLE, STANDARD PARTS			
1	34-06051-36	Rivnut, 1/4-20	A/R
2	34-06053-03	Washer, 0.250 ID X 1.000 OD	A/R
3	69NT35-2692-1	Washer, Fender, 1/4	A/R
4	34-00663-11	Washer, Lock, 1/4 Spring	A/R
5	66U1-5361-25	Screw, Cap HXHD, 1/4-20 X 0.75	A/R
BLUE PANEL			
-	79-66635-00	Grille and Venturi Assembly, Blue - Includes:	1
6	68-12635-05	Panel Venturi	1
7	86-04637-00	Grille Assembly	1
8	34-00928-07	Rivet, Blind	8
9	62-11273-00	Label, Rotation	1
WHITE PANEL			
-	79-66635-01	Grille and Venturi Assembly, White - Includes	1
6	68-12635-22	Panel Venturi	1
7	86-04637-02	Grille Assembly	1
8	34-00928-07	Rivet, Blind	8
9	62-11273-00	Label, Rotation	1
ORANGE PANEL			
-	79-66635-02	Grille and Venturi Assembly, Orange - Includes	1
6	68-12635-06	Panel Venturi	1
7	86-04637-01	Grille Assembly	1
8	34-00928-07	Rivet, Blind	8
9	62-11273-00	Label, Rotation	1

2.11 CONDENSER FAN GRILLE ASSEMBLY (Continued)			
Item	Part Number	Description	Qty
OPTION H - HINGED CONDENSER FAN GRILLE, STANDARD PARTS			
8	34-00928-07	Rivet, Blind	8
10	58-04101-07	Protector	4
11	44-00374-00	Hinge	2
12	34-06179-00	Screw, HXHD, Sems #10-24 x 7/16	4
13	34-06169-00	Washer, Retaining, SST	2
14	34-06053-03	Washer, Mylar, 1/4 ID X 1.00 OD	4
15	69NT35-2692-1	Washer, Fender, 1/4, SST	2
BLUE PANEL WITH SLOTTED SCREW			
Use Standard Parts with Items Below:			
-	79-66635-03	Grille and Venturi Assembly, Blue, Slotted Screw - Includes	1
16	68-12635-03	Panel, Venturi	1
17	86-04637-00	Grille Assembly	1
18	66U1-6811-8	Screw, Retaining, SST	2
WHITE PANEL WITH SLOTTED SCREW			
Use Standard Parts with Items Below:			
-	79-66635-04	Grille and Venturi Assembly, White, Slotted Screw - Includes	1
16	68-12635-21	Panel, Venturi	1
17	86-04637-02	Grille Assembly	1
18	66U1-6811-8	Screw, Retaining	2
ORANGE PANEL WITH SLOTTED SCREW			
Use Standard Parts with Items Below:			
-	79-66635-05	Grille and Venturi Assembly, Orange, Slotted Screw - Includes	1
16	68-12635-04	Panel, Venturi	1
17	86-04637-01	Grille Assembly	1
18	66U1-6811-8	Screw, Retaining	2
BLUE PANEL WITH PHILLIPS SCREW			
Use Standard Parts with Items Below:			
-	79-66635-06	Grille and Venturi Assembly, Blue, Phillips Screw - Includes	1
16	68-12635-03	Panel, Venturi	1
17	86-04637-00	Grille Assembly	1
19	66U1-6811-12	Screw, Retaining	2
WHITE PANEL WITH PHILLIPS SCREW			
Use Standard Parts with Items Below:			
-	79-66635-07	Grille and Venturi Assembly, White, Phillips Screw - Includes	1
16	68-12635-21	Panel, Venturi	1
17	86-04637-02	Grille Assembly	1
19	66U1-6811-12	Screw, Retaining	2
ORANGE PANEL WITH PHILLIPS SCREW			
Use Standard Parts with Items Below:			
-	79-66635-08	Grille and Venturi Assembly, Orange, Phillips Screw - Includes	1
16	68-12635-04	Panel, Venturi	1
17	86-04637-01	Grille Assembly	1
19	66U1-6811-12	Screw, Retaining	2

2.12 COMPRESSOR TUBING

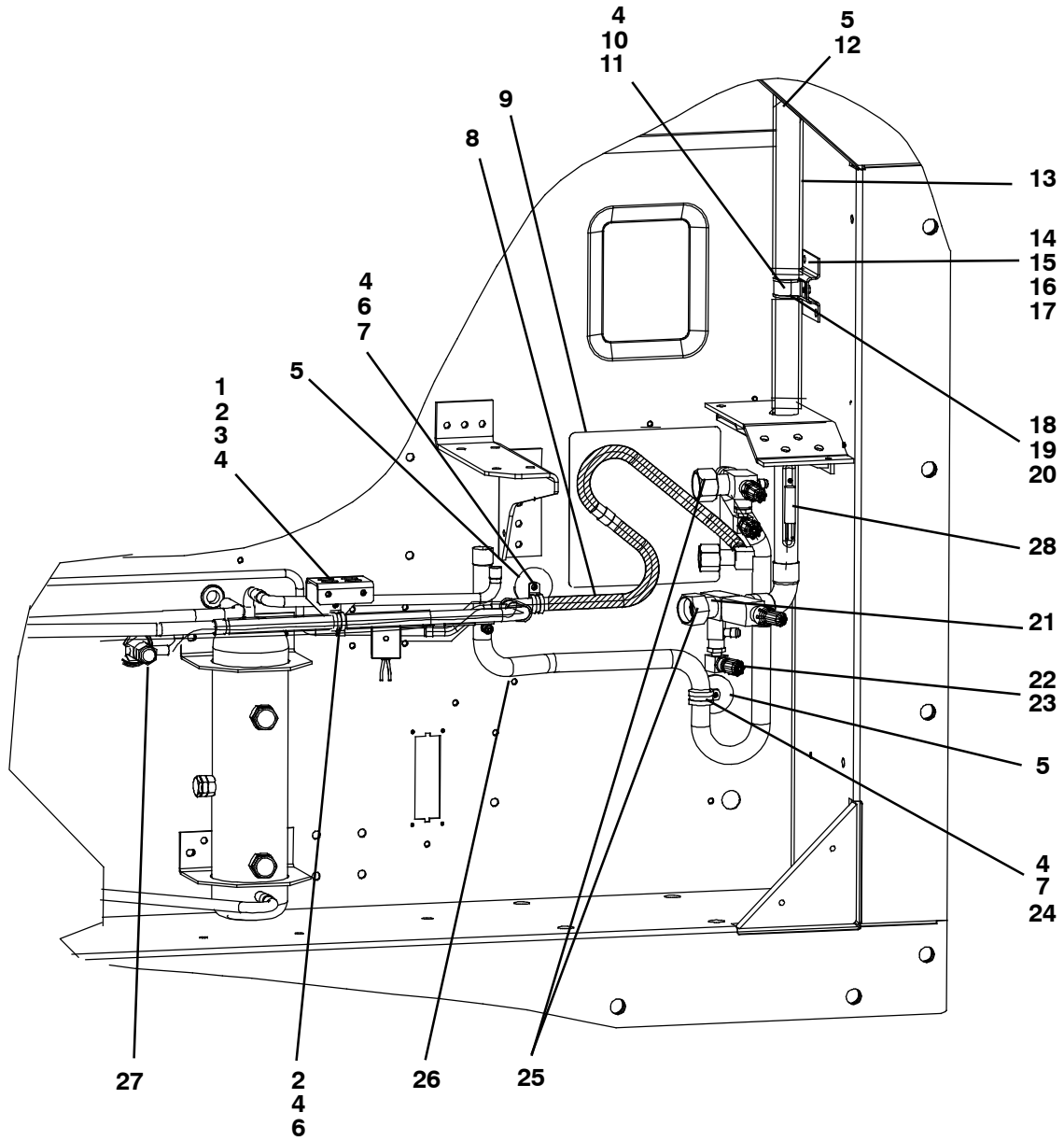

2.12 COMPRESSOR TUBING (Continued)			
Item	Part Number	Description	Qty
1	68-14142-00	Bracket, White	1
	68-14142-01	Bracket, Orange	1
2	66U1-5371-6	Screw, HXHD 10-24 X 0.750	3
3	66U1-5321-8	Washer, Plain #10	2
4	34-06053-05	Washer 0.205 ID X 0.600 OD	7
5	34-06295-00	Washer Fender #10-1.690-2.000	2
6	34-00373-07	Tube Clamp	2
7	66U1-5371-10	Screw Machine HXHD #10-24 X 1.00	2
8	81-01996-01	Tube Assembly Econo. with Fitting	1
9	58-04026-26	Protector 7.50 X 7.50	1
10	66U1-5371-7	Screw, HXHD #10-24 X 0.500	2
11	KA-66FA-060	Tube Clamp	1
12	66CH-11172	Flexible Trim	1
13	81-01980-01	Tube Assembly Suction with Fitting	1
14	66U1-5361-25	Screw, HXHD 1/4-20 X 0.75	2
15	66U1-5321-7	Washer, Plain 1/4	2
16	34-06053-00	Washer 0.250 ID X 0.800 OD	2
17	68-14129-00	Bracket, White	1
	68-14129-01	Bracket, Orange	1
18	66U1-3882-3	Wire Tie 1/16-4.0 Self-Linking	12
19	42-00660-00	Insulation, Tube Pre-Taped	1
20	42-00659-00	Insulation, Assembly Pre-Taped	1
21	42-00384-01	Seal 1-14	1
22	40-00542-00	Elbow Adapter	1
23	40-00520-02	Cap	1
24	66U1-3632-20	Tube Clamp	1
25	42-00384-02	Seal 1 1/4-12	2
26	81-01907-01	Tube Assembly Discharge with Fitting	1
27	58-00969-00	Wire Tie 2.80 Dia	7
REFRIGERATION TEMPERATURE SENSORS			
28	12-00493-08	Sensor, Thermistor (CPDS)	1
-	-	Sensor, Thermistor (CPSS) See Section 2.20	1

2.13 RECEIVER

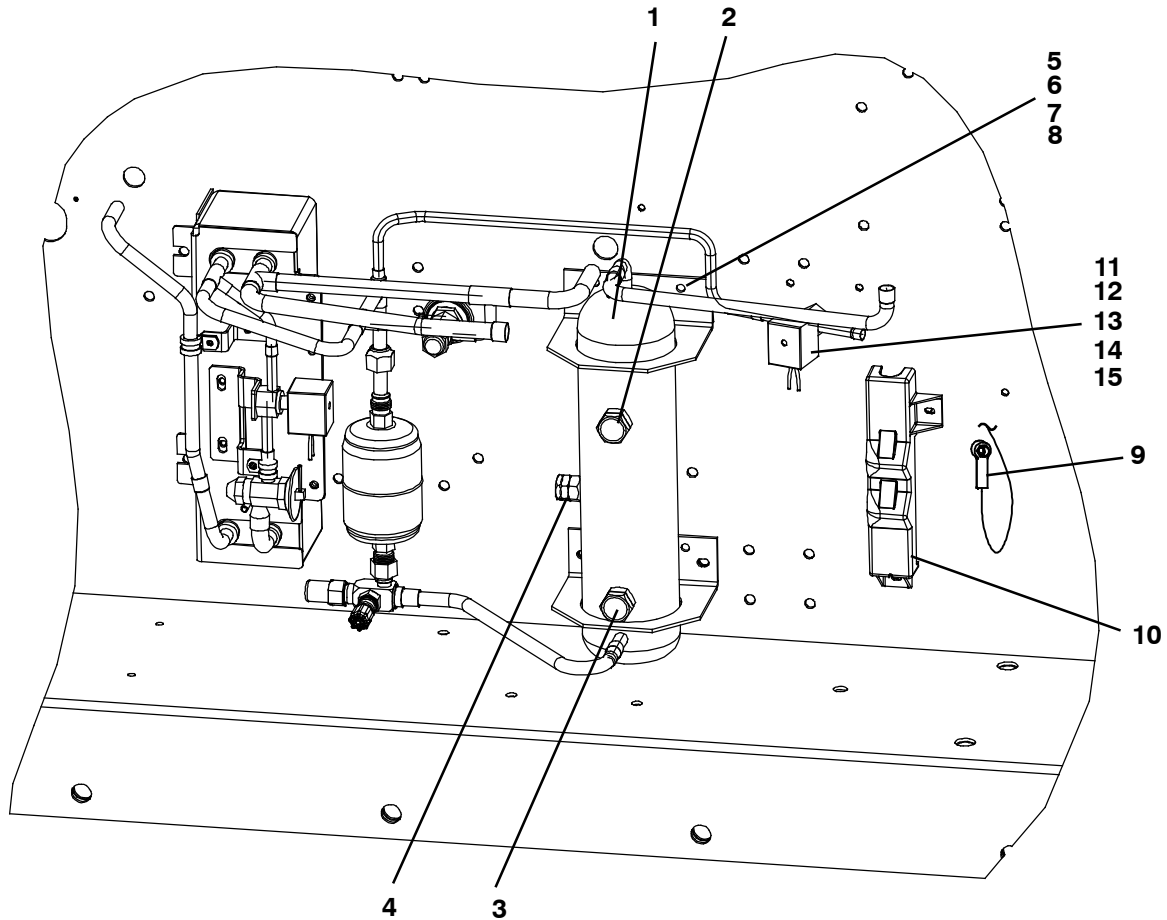

Item	Part Number	Description	Qty
1	79-01785-01	Receiver Assembly - Includes:	1
2	14-00220-04	Glass, Sight	1
3	14-00221-04	Indicator, Moisture-Liquid	1
4	14-01032-14	Plug, Fusible, 3/8 NPT- Brass	1
5	58-04026-61	Protector, Mylar	2
6	66U1-5361-25	Screw, HXHD, 1/4-20 X 3/4 Long - SST	4
7	66U1-5321-7	Washer, Flat, 1/4 - SST	4
8	34-06035-00	Washer, Mylar	4
9	12-00495-02SV	Sensor, Ambient Thermistor (AMBS)	1
10	-	See Section 2.16 for Sensor Assembly and Related Parts	-
11	34-06053-11	Washer, Mylar, 0.205 ID X 0.60 OD	4
12	66U1-5321-8	Washer, Plain, #10 - SST	3
13	14-00285-00	Unloader Solenoid Valve	1
14	14-01091-01	Coil, Unloader Solenoid Valve	1
15	68-15148-00	Bracket, White	1
	68-15148-01	Bracket, Orange	1

2.14 WATER-COOLED CONDENSER

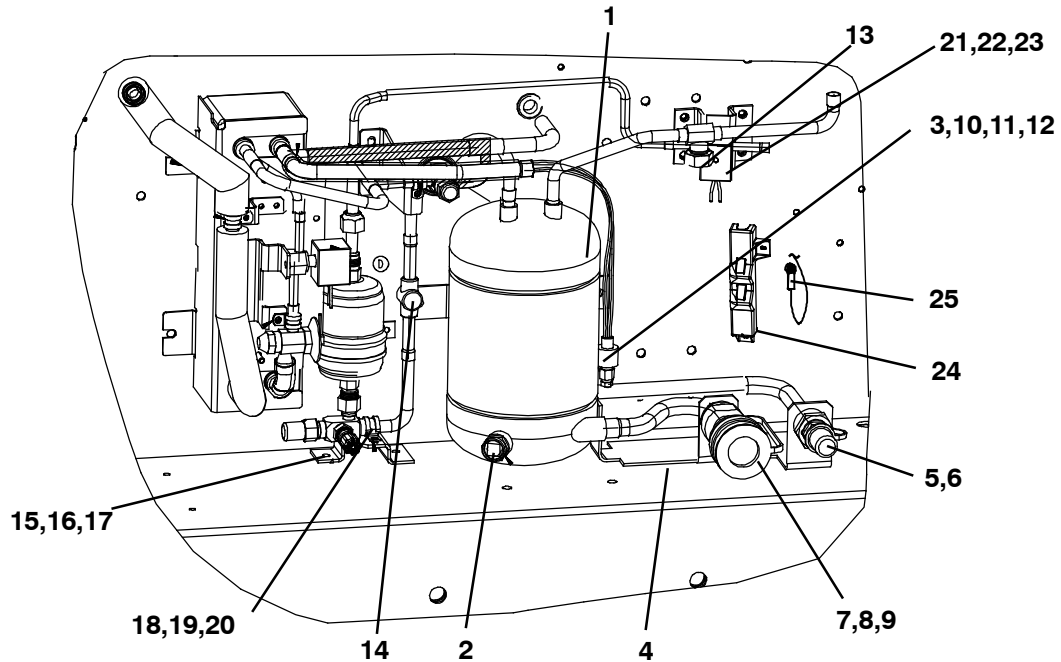

Item	Part Number	Description	Qty
-	76-00734-00	Kit, Condenser/Receiver (For Field Installation) - Includes:	1
1	69NT42-954-4	Condenser/Receiver - Includes:	1
2	14-00220-00	Sight Glass, with Red Balls, 1/2 NPT	1
3	58-00956-00	Protector, Mylar	2
4	58-04436-00	Protector, Mylar	1
5	66U1-2763-5	Coupling (Water-In)	1
6	66U2-1142	Cap, Dust	1
7	40-01129-00	Coupling, Self Draining - Includes:	1
8	42-50000-00	Seal, O-Ring	1
9	66U2-1152	Cap, Dust	1
10	12-01071-01SV	Switch, Water Pressure OPTION W	1
11	66U2-1132-1	Connector	2
12	66U1-3803	Heat Shrink	2
13	14-00215-05	Disc, Rupture, 3/8 NPT	1
14	14-01092-15	Indicator, Liquid Moisture - Brass	1
15	40-01129-00	Tee, 1/2 X 1/2 X 3/8 NPT - Brass	1
16	66U1-5371-6	Screw, HXHD, #10-24 X 3/4 Long - SST	4
17	34-00667-09	Nut, Self-Lock, #10-24 - SST	4
18	34-06053-11	Washer, Mylar, 0.205 ID X 0.60 OD	4
19	66U1-5321-8	Washer, Plain, #10 - SST	3
20	34-00373-05	Clamp, Cushion, 1/2 Diameter	1
21	14-00285-00	Unloader Solenoid Valve	1
22	14-01091-01	Coil, Unloader Solenoid Valve	1
23	68-15148-00	Bracket, White	1
	68-15148-01	Bracket, Orange	1
24	-	See Section 2.16 for Sensor Assembly and Related Parts	1
25	12-00495-02SV	Sensor, Ambient Thermistor (AMBS)	-

2.15 ECONOMIZER, ECONOMIZER EXPANSION VALVE, ECONOMIZER SOLENOID VALVE AND FILTER DRIER

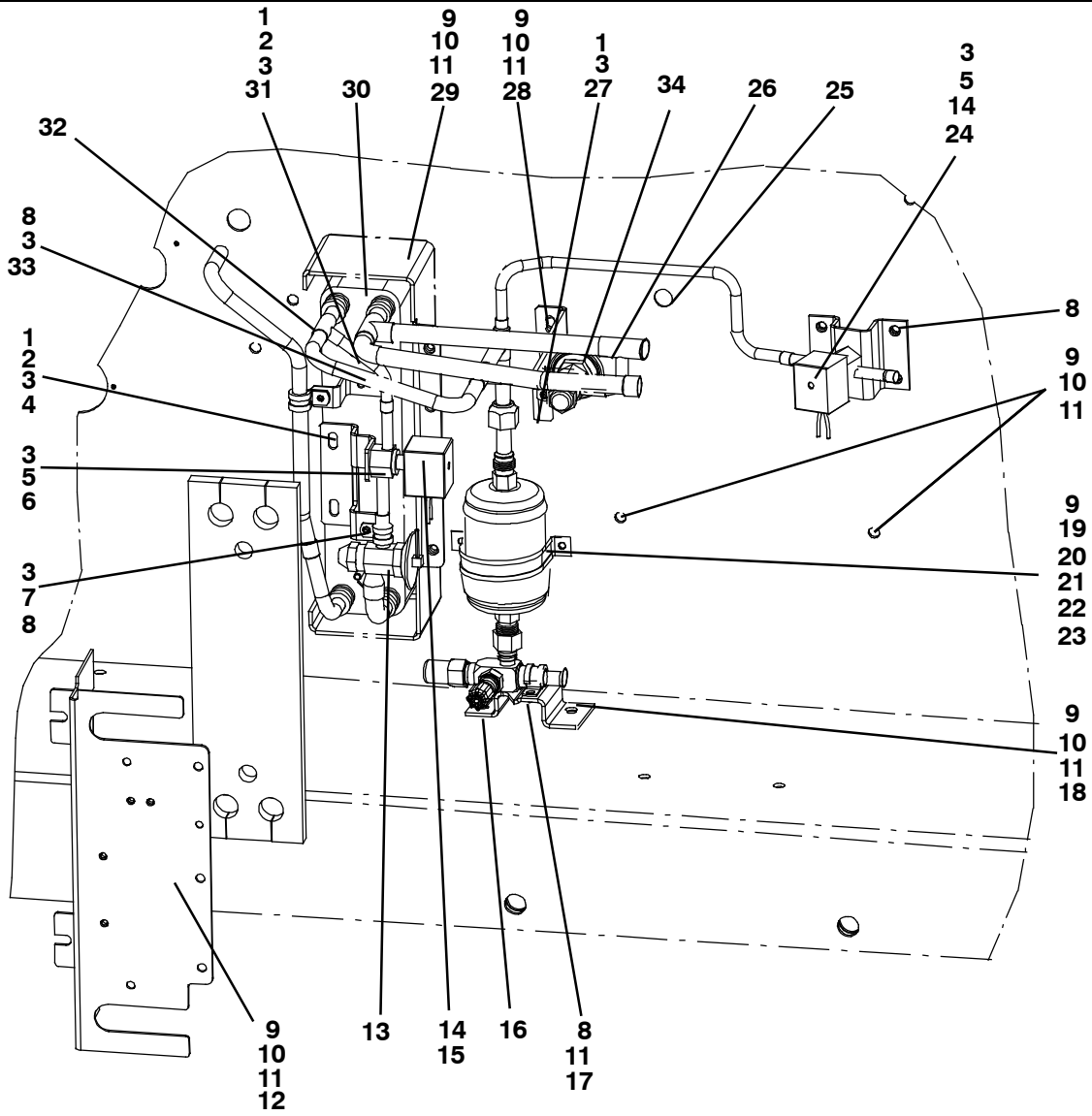

2.15 ECONOMIZER, ECONOMIZER EXPANSION VALVE, ECONOMIZER SOLENOID VALVE AND FILTER DRIER (Continued)			
Item	Part Number	Description	Qty
1	66U1-5371-7	Screw Mach HXHD #10-24 X 0.500	3
2	66U1-5321-8	Washer, Plain #10	4
3	34-06053-05	Washer 0.205 ID X 0.600	11
4	68-14278-00	Bracket, White	1
	68-14278-01	Bracket, Orange	1
5	58-04026-59	Protector Valve	2
6	14-01090-12	Solenoid Valve - Economizer	1
7	34-00373-54	Clamp, Tube Cushion	1
8	66U1-5371-6	Screw Mach HXHD #10-24 X 0.750	8
9	66U1-5361-25	Screw Cap HXHD 1/4-20 X 0.75	34
10	66U1-5321-7	Washer, Plain 1/4	41
11	34-06053-00	Washer 0.250 ID X 0.800	41
12	68-14269-01	Cover, White	1
	68-14269-02	Cover, Orange	1
13	14-00232-31	Valve, Thermal Expansion - Economizer	1
14	14-01091-01	Coil Solenoid Valve - Economizer & Liquid Injection	2
15	66U1-3803	Tube, Heat Shrink	4
16	40-00520-01	Coupling with Cap	1
17	66U1-5732-1	Clamp, Tube	1
18	68-14989-00	Bracket	1
19	69NP20-1031	Clamp, Tube Cushion	1
20	66U1-2552-133	Gasket Neoprene	1
21	14-50341-02SV	Filter Drier - Includes:	1
22	14-00341-07	Filter Drier, 1/2 Flare, O-Ring, Single - Includes:	1
23	14-00284-20	O-Ring, Filter Drier	1
-	14-00341-07PK25	Filter Drier, 1/2 Flare, O-Ring, 25 Pack - Includes:	A/R
-	14-00284-20	O-Ring, Filter Drier	25
24	14-00285-00	Solenoid Valve - Liquid Injection	1
25	58-00065-27	Grommet 0.62 ID X 0.88 OD	1
26	DE40BA3-03	Tee, Reducing 5/8 X 5/8 X 3/8	1
27	34-00373-53	Clamp, Tube Cushion 0.38 Dia	1
28	68-15001-00	Bracket, White	1
	68-15001-01	Bracket, Orange	1
29	68-14268-00	Bracket, White	1
	68-14268-01	Bracket, Orange	1
30	81-01539-20	Heat Exchanger Assembly	4
31	68-14413-00	Bracket, White	1
	68-14413-01	Bracket, Orange	1
32	DE40BA-203	Tee, Reducing 1/2 X 1/2 X 3/8	2
33	44-00370-03	Clamp Cushioned	1
34	14-00212-04	Valve, Thermal Expansion - Quench	1

2.16 SRS AND STS

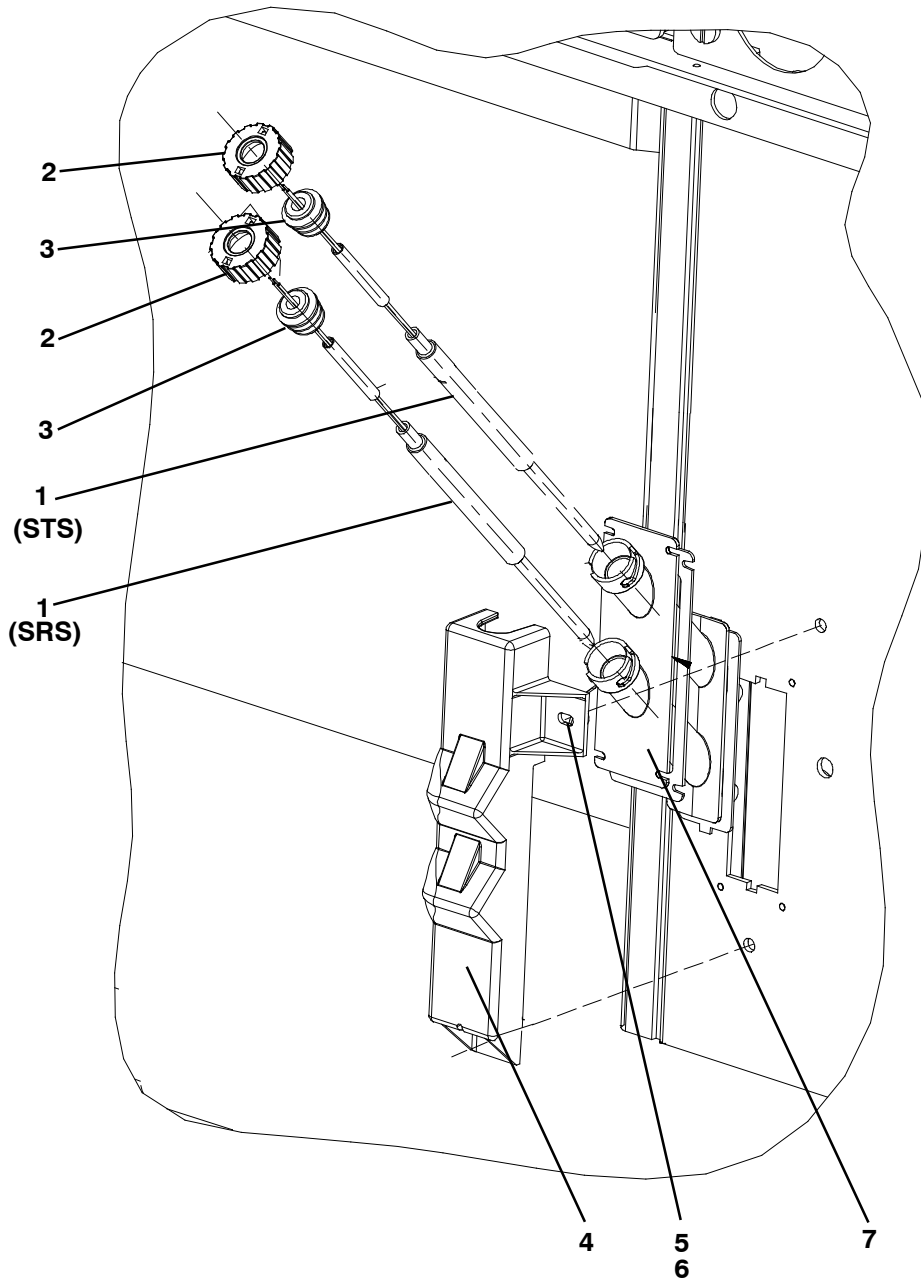

Item	Part Number	Description	Qty
1	12-00395-01SV	Sensor Assembly (STS & SRS)	1
2	58-04277-00SV	Cap, Probe - Includes:	2
3	58-04278-00	Grommet NSS	2
4	58-04279-00	Cover, Probe	1
5	66U1-5321-7	Washer, Flat, 1/4 - SST	2
6	66U1-5371-7	Screw, Machine, HXHD, #10-24 X 0.50 Long - SST	2
7	58-04276-00	Holder, Probe	1

2.17 EVAPORATOR FAN ASSEMBLY

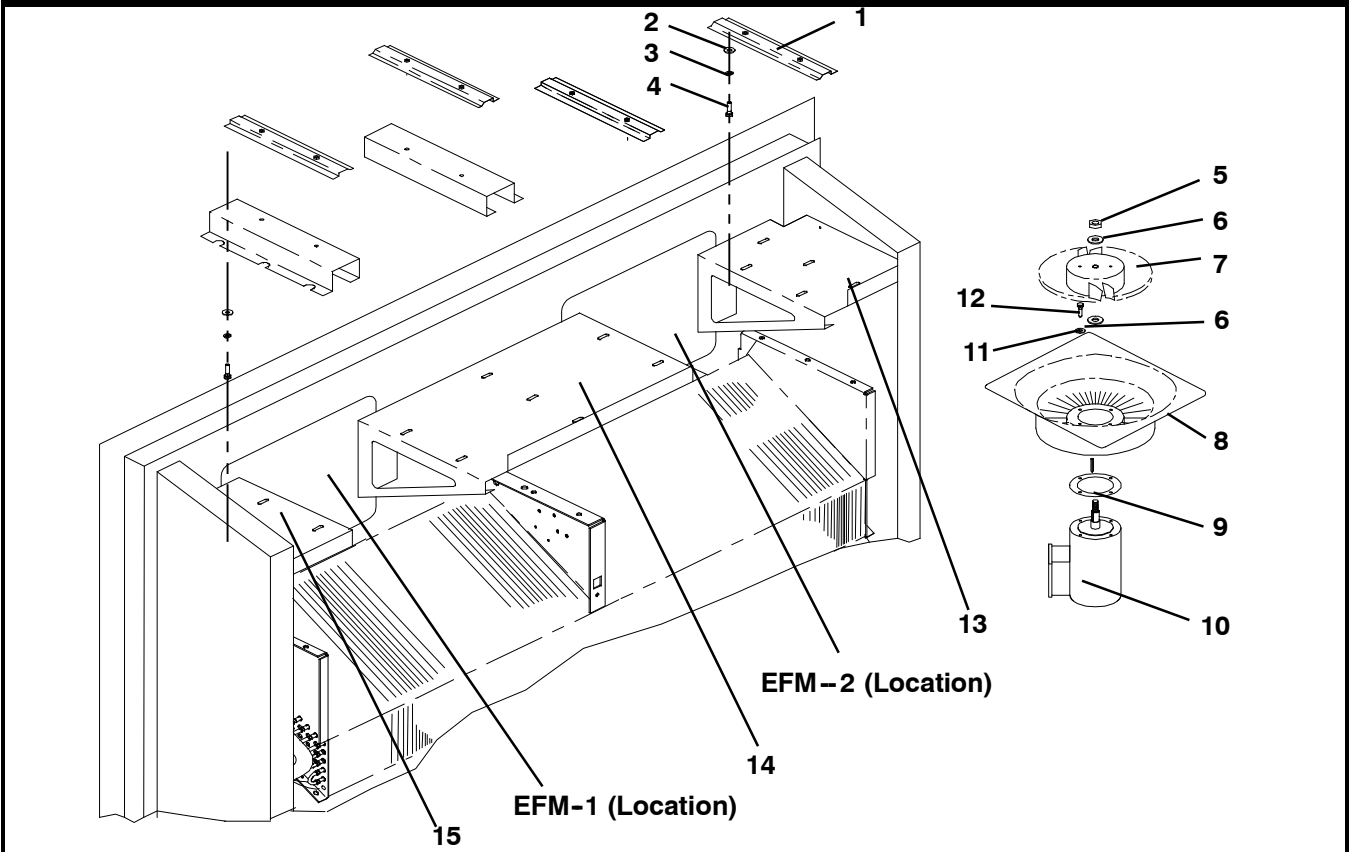

Item	Part Number	Description	Qty
1	69NT43-295	Mounting Bracket, Evaporator Fan Assembly	4
2	69NT35-2692-1	Washer, Fender	8
3	34-00663-11	Washer, Lock, 1/4 - SST	8
4	34-06165-09	Screw, HXHD, 1/4-20 X 1-1/4 Long - SST	8
5	34-00795-17	Nut, Self-Locking, 5/8-18 - SST	2
6	34-00616-06	Washer, Special, 5/8 - SST	4
7	38-00557-00	Fan, Evaporator	2
8	48-00262-00	Stator, Evaporator	2
9	58-04066-00	Protector - Mylar	2
10	54-00585-20	Motor, Evaporator Fan - Includes:	2
NS	04-50027-00	Bearing, Front (Shaft End)	1
NS	22-50088-00	Capacitor (20 μ F) High Speed	1
NS	22-01613-34	Pin #16	1
NS	22-01892-00	Plug Assembly, Motor (Located on Wire Harness) - Includes:	1
NS	22-01614-03	Plug	1
NS	22-01613-15	Contacts	A/R
NS	22-01892-01	Receptacle Assembly, Motor - Includes:	1
NS	22-01614-02	Receptacle	1
NS	22-01614-05	Strain Relief	1
NS	22-01613-14	Contacts	A/R
11	66U1-5321-3	Washer, Flat, 1/4 - SST	8
12	34-06165-09	Screw, HXHD, 1/4-20 X 1-1/8 Long - SST	8
13	68-13983-00	Fan Deck, Right	1
14	68-13979-00	Fan Deck, Center	1
15	68-13984-00	Fan Deck, Left	1

2.18 UPPER FRESH AIR MAKE-UP AND ACCESS PANEL

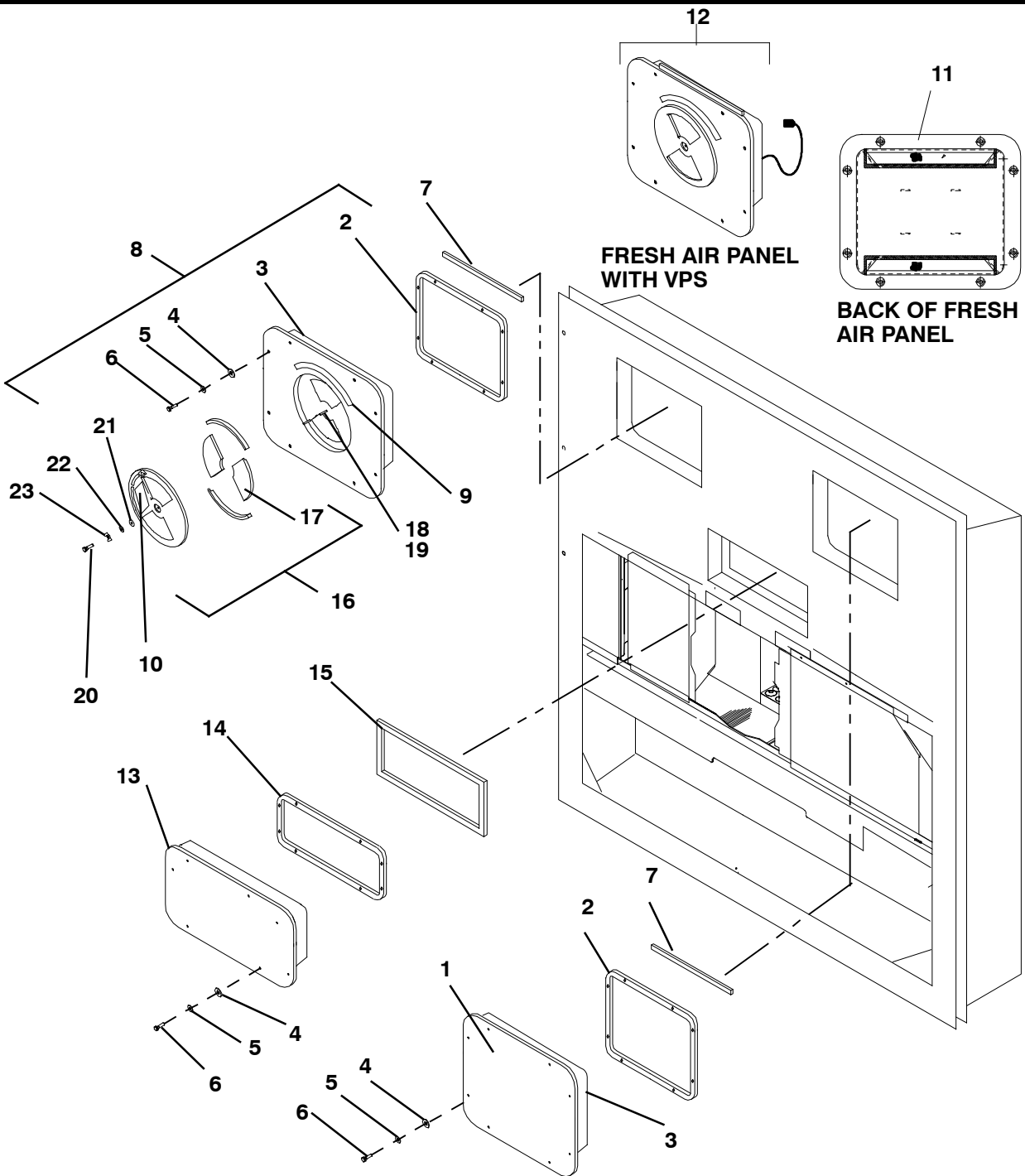

Item	Part Number	Description	Qty
OPTION 1 - NONE (PLAIN EVAPORATOR ACCESS PANEL)			
1	79-01697-06SV	Panel, Access - Includes:	A/R
2	42-00296-01	Gasket	1
3	42-00327-00	Gasket, - 0.26 X 0.50 Half Round	1
4	34-06053-13	Washer, Mylar, 1/4 ID X 0.80 OD	8
5	34-006212-12	Washer, Flat, 1/4 - SST	8
6	34-06154-00	Screw, HXHD, 1/4-20 X 1.00 Long - TIR	8
7	66U1-2552-185	Gasket, 0.75 X 1.5 X 16.63	1

2.18 UPPER FRESH AIR MAKE-UP AND ACCESS PANEL (Continued)			
Item	Part Number	Description	Qty
OPTION 2 - FRESH AIR MAKEUP INSTALLED			
7	66U1-2552-185	Gasket, 0.75 X 1.5 X 16.63	1
8	79-01694-00	Panel, Fresh Air Make-up w/Retaining Washers - Includes:	A/R
2	42-00296-01	Gasket	1
3	42-00327-00	Gasket, 0.26 X 0.50 Half Round	1
9	-	Label, Fresh Air (See Section 2.29 for Language Selection)	1
10	62-02783-00	Label, Fresh Air	1
21	34-06053-19	Washer, Mylar, 1.00 OD X 0.312 ID	1
22	66U1-5321-13	Washer, Flat, 5/16 - SST	1
23	66U1-5362-2	Nut, Wing, 5/16-18 - SST	1
OPTION 3 - FRESH AIR MAKEUP AND SCREENS INSTALLED - USE ALL OF OPTION 2 AND ITEM BELOW			
11	58-04251-00	Screen, Medfly	2
OPTION 4 - FRESH AIR MAKEUP AND VENT POSITIONING SENSOR (VPS) INSTALLED			
7	66U1-2552-185	Gasket, 0.75 X 1.5 X 16.63	1
9	-	Label, Fresh Air (See Section 2.29 for Language Selection)	1
10	62-02783-00	Label, Fresh Air	1
12	79-01902-00	Panel, Fresh Air Make-up with VPS, White - Includes:	A/R
	79-01902-01	Panel, Fresh Air Make-up with VPS, Orange - Includes:	A/R
2	42-00296-01	Gasket	1
3	42-00327-00	Gasket, - 0.26 X 0.50 Half Round	1
21	34-06053-19	Washer, Mylar, 1.00 OD X 0.312 ID	1
22	66U1-5321-13	Washer, Flat, 5/16 - SST	1
23	66U1-5362-2	Nut, Wing, 5/16-18 - SST	1
HEATER ACCESS PANEL			
5	34-06053-13	Washer, Flat, 1/4 - SST	8
4	34-06053-00	Washer, Mylar, 1/4 ID X 0.80 OD	8
6	34-06154-00	Screw, HXHD, 1/4-20 X 1.00 Long - TIR	8
13	79-01697-14SV	Panel, Access - Includes:	1
14	42-01052-02	Gasket	1
15	34-06212-12	Gasket, Access Panel	1
STUD ASSEMBLY KITS (REPLACEMENT)			
16	74-00201-02	Kit, Gasket and Stud Assembly (See NOTE 1) - Includes:	1
17	42-00407-00	Gasket (One Piece)	1
18	74-00201-01	Kit, Disc and Stud Assembly (See NOTE 2) - Includes:	1
19	NSS	Stud Assembly, 5/16-18	1
20	34-06185-01	Screw, Machine Pan Head, #8-32 X 1/2 Long - SST	1
21	34-06053-19	Washer, Mylar, 1.00 OD X 0.312 ID	1
22	66U1-5321-13	Washer, Flat, 5/16 - SST	1
23	66U1-5362-2	Nut, Wing, 5/16-18 - SST	1
NOTES			
1. Disc and stud assembly kit, which will modify stud to 5/16-18, also includes new disc and gasket.			
2. Must order 74-00201-01 stud assembly kit, which will modify stud to 5/16-18, and include 42-00407-01 (1 piece) gasket.			

2.19 LOWER FRESH AIR MAKE-UP VENT

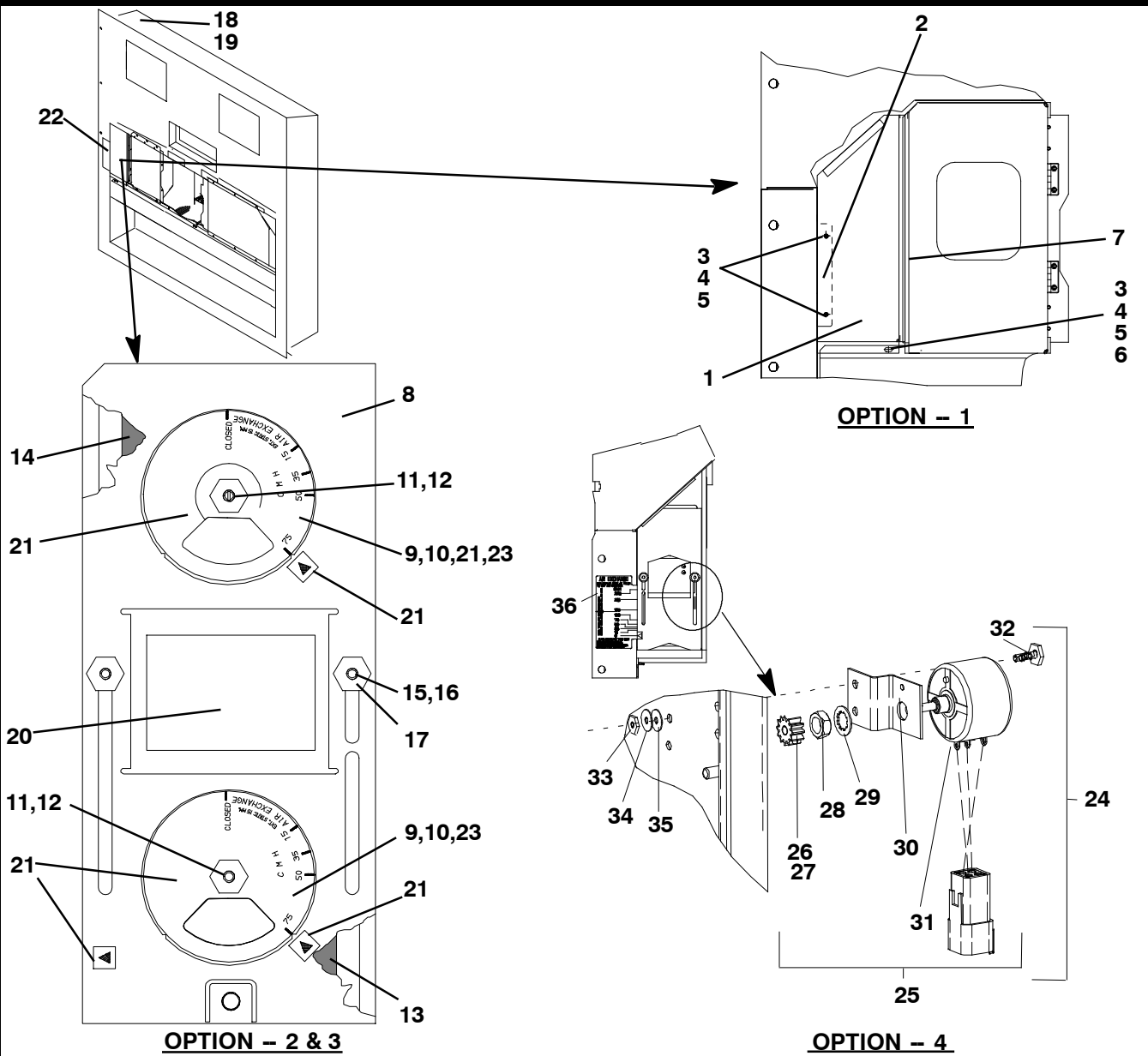

Item	Part Number	Description	Qty
OPTION 1 - NONE			
1	69NT35-4047	Panel, Blank	1
2	69NT43-307	Bracket, Panel	1
3	66U1-5361-25	Screw, HXHD, 1/4-20 X 3/4 Long - SST	3
4	34-06053-18	Washer, Mylar, 1/4 ID X 1.00 OD	3
5	66U1-5321-3	Washer, Flat, 1/4, Type A- SST	3
6	69NT35-2692-1	Washer, Fender 1/4 - SST	1
7	42-00465-00	Gasket	1
OPTION 2 - LOWER FRESH AIR INSTALLED			
8	69NT41-852-1	Cover, Fresh Air Makeup - Includes:	1
9	69NT40-976-3	Cover Assembly, Air Bleed - Includes:	2
10	42-00233-01	Gasket, Air Exchange	2
11	34-06092-00	Nut, Hex, 1/4-20 UNC-2B - SST	2
	34-06183-00	Nut, Hex, (with mini handle), 1/4-20 UNC-2B - SST	2
12	34-06053-00	Washer, Mylar, 1/4 ID X 1.00 OD	2

2.19 LOWER FRESH AIR MAKE-UP VENT (Continued)			
Item	Part Number	Description	Qty
13	42-00295-01	Gasket, Cover	1
14	42-00295-00	Gasket, Cover	1
15	69NT41-782	Bushing	2
16	66U1-5321-7	Washer, Flat, 1/4 - SST	2
17	34-06092-00	Nut, Hex, 1/4-20 UNC-2B - SST	A/R
	34-06183-00	Nut, Hex, (with mini handle),1/4-20 UNC-2B - SST	A/R
18	69NT35-8348	Baffle, Unpainted	1
19	34-00928-09	Rivet, Blind, 0.156 Diameter, Grip Range - 3/16-1/4	4
20	69NT35-7012	Label, Fresh Air	1
21	76-50116-03	Label Kit - Includes:	1
	62-10540-04	Label, Air Exchange, CMH - <i>English</i>	2
	66CH1-1002-33	Label, Arrow	3
	76-50116-00	Label Kit - Includes:	1
	69NT35-1417	Label, Air Exchange, CMH - <i>English</i> (Maersk Specification)	2
	66CH1-1002-33	Label, Arrow (Maersk Specification)	3
	76-50116-01	Label Kit - Includes:	1
	69NT35-9238	Label, Air Exchange, CFM - <i>English/Spanish</i>	2
	66CH1-1002-33	Label, Arrow	3
	76-50116-02	Label Kit - Includes:	1
	62-10540-00	Label, Air Exchange, CMH - <i>English/Spanish/Chinese</i>	2
	66CH1-1002-33	Label, Arrow	3
	76-50116-04	Label Kit - Includes:	1
	62-10540-00	Label, Air Exchange, CMH - <i>English/Spanish/Chinese</i> (NYK Specification)	2
62-10381-00	Label, Arrow (NYK Specification)	3	
22	69NT35-1287-1	Label, Fresh Air Exchange, CMH - <i>English</i> (Maersk Specification)	1
	69NT35-9228	Label, Fresh Air Exchange, CFM - <i>English/Spanish</i>	1
	62-10537-00	Label, Fresh Air Exchange, CMH - <i>English/Japanese/Chinese</i>	1
	62-10381-00	Label, Fresh Air Exchange, CMH - <i>English</i>	1
OPTION 3 - LOWER FRESH AIR INSTALLED WITH SCREENS - USE ALL OF OPTION 2 AND ITEM BELOW			
23	58-04263-01	Screen Assembly, Medfly	2
OPTION 4 - LOWER FRESH AIR INSTALLED WITH VENT POSITION SENSOR			
24	76-50136-00	Assembly, Vent Position Sensor - Includes:	1
25	79-01925-00	Sensor Assembly - Includes:	1
26	48-00377-00	Gear, 69NT, Auto LFA	1
27	34-06262-00	Screw, Set #8- 32 X 0.156 Long	1
28	34-06287-00	Nut, Hex Jam 3/8- 32	1
29	34-06286-00	Washer, Lock 3/8- 32	1
30	68-14955-00	Bracket, 0.063 Thick SST	1
31	10-00455-00	Sensor, LVPS, Potentiometer	1
32	66U1-5371-7	Screw, HXHD 10-24 X 1/2 gl. SST	2
33	34-00666-09	Nut, Hex, 10-24 UNC-2B - SST	2
34	66U1-5321-8	Washer, Flat, 1/2, Type A - SST	2
35	34-06053-04	Washer, Mylar	2
36	62-10984-00	Label, LVPS, Air Exchange	1
37	79-01934-00	Assembly, Slide	1

2.20 EVAPORATOR COIL - REAR PANELS REMOVED

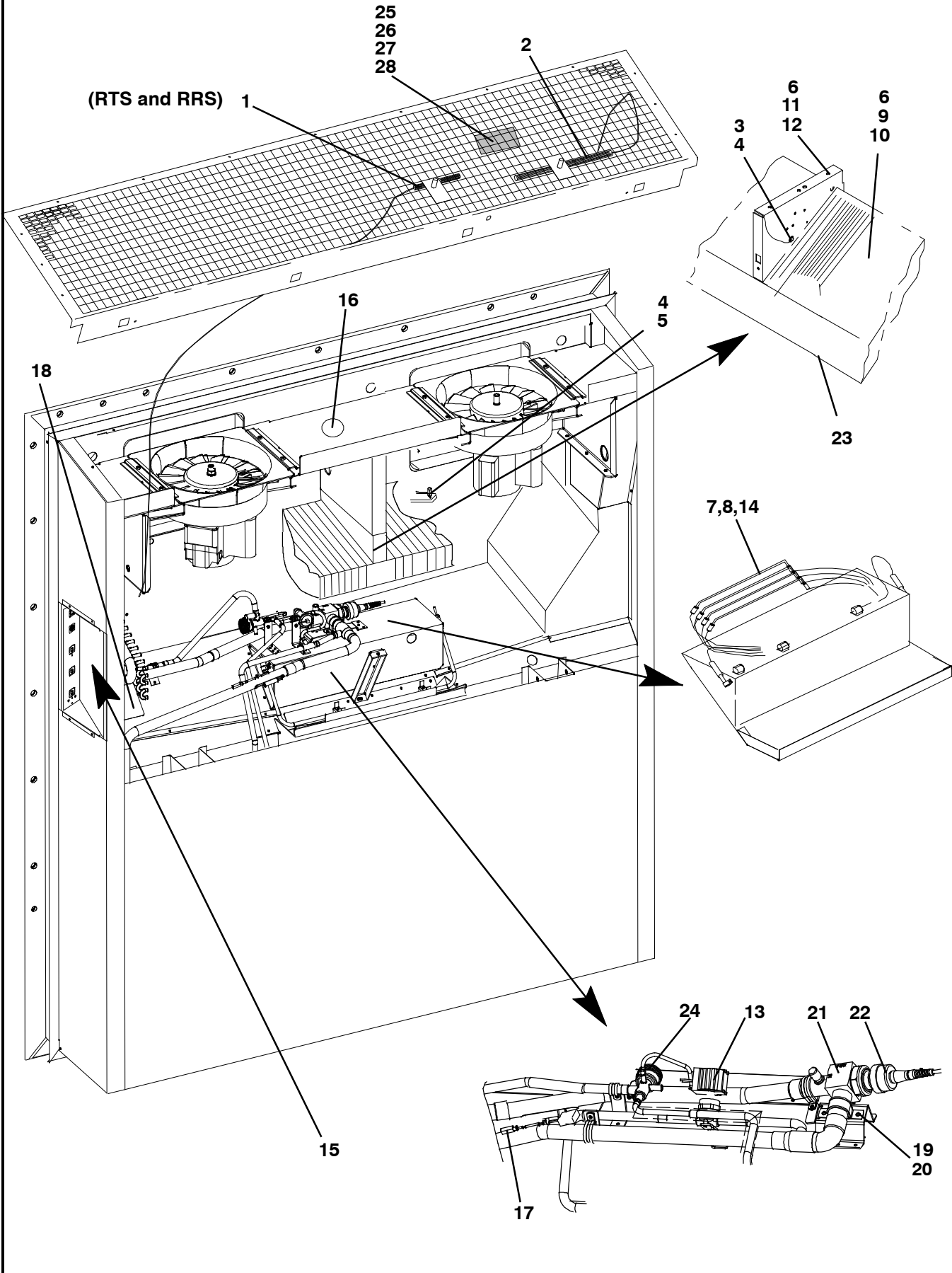

2.20 EVAPORATOR COIL - REAR PANELS REMOVED (Continued)			
Item	Part Number	Description	Qty
1	12-00500-01SV	Sensor Assembly (RRS & RTS)	1
2	-	Sensor, Thermistor, (Temperature Recorder)	-
3	12-00495-02SV	Sensor, Thermistor, Defrost (DTS)	1
4	34-01178-22	Screw, HXHD, #8-32 X 1/2 Long - SST	3
5	66U1-6912-16	Thermostat, Heat Termination (HTT)	1
6	AU11JR171	Washer, Lock, 1/4 - SST	10
7	69NT35-6522	Retainer (For Heaters)	3
8	69NT35-6532	Clip (For Heaters)	4
9	69NT35-2692-1	Washer, Flat, 1/4 - SST	2
10	66U1-5371-13	Screw, HXHD, #10-24 X 1.25 Long - SST	2
11	66U1-5361-25	Cap screw, HXHD, 1/4-20 X 3/4 Long - SST	9
12	66U1-5321-3	Washer, Flat, 1/4 - SST	A/R
13	14-01090-11	Valve, Unloader	1
	14-01091-02	Coil, Unloader Valve	1
14	24-00006-02	Heater, Evaporator Coil	4
15	-	USDA Option - Refer to Section 2.21	-
16	12-00493-09	Plug, Hole (2 Inch diameter) (Located on Fan Deck)	1
17	12-00493-06	Sensor, Thermistor, (CPSS)	1
18	58-04026-26	Protector, Mylar	2
19	KA66FA138	Clamp, Tube 1 3/8 2 Holes	1
20	66U1-5371-7	Screw, Machine, HXHD, #10-24 X 0.50 Long - SST	2
21	14-00263-05	Valve, Stepper Motor - Includes:	1
22	14-00263-20	Piston and Motor Assembly - Includes:	1
NS	22-02392-03	Connector (To Expansion Controller Module)	1
NS	22-02393-01	Pin, 18-20 Gauge (Used on 22-02392-03)	4
NS	22-02394-03	Seal (Used on 22-02392-03)	4
23	08-00297-20	Coil, Evaporator (Does not include thermostats or heaters)	1
24	14-00273-02	Valve, Thermostatic Expansion, Hermetic	1
DEHUMIDIFICATION			
-	76-00675-01	Kit, Humidity Sensor (Field installation, units provisioned for - See Unit Matrix) - Includes:	-
25	10-00413-00	Sensor, Humidity (HS)	1
26	66U1-5371-10	Screw, HXHD, #10-24 X 1.00 Long - SST	4
27	66U1-5321-8	Washer, Flat, #10 - SST	2
28	68-13181-00	Bracket Assembly, Humidity Sensor	1

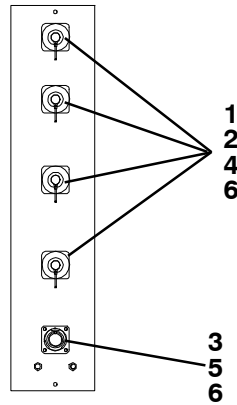
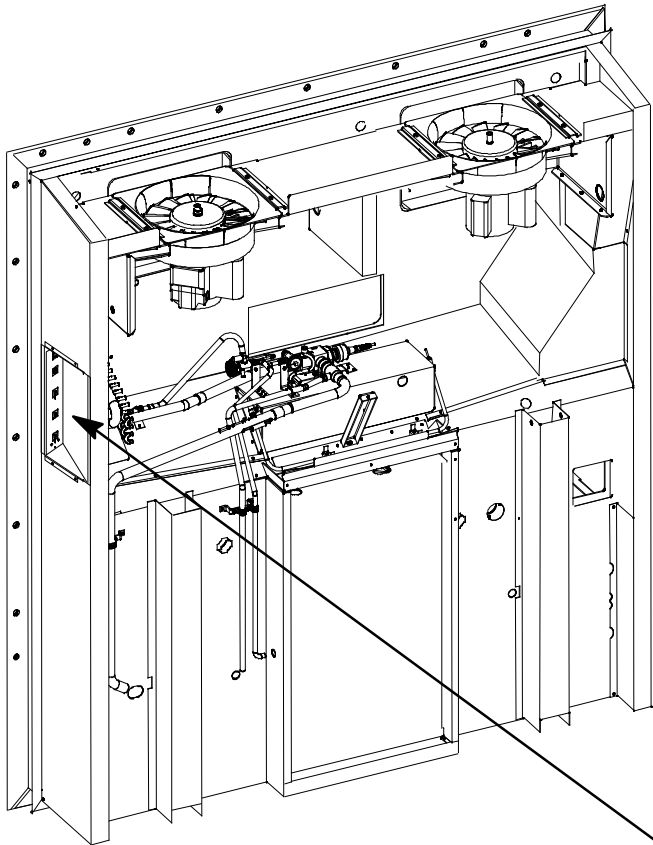

OPTION - D

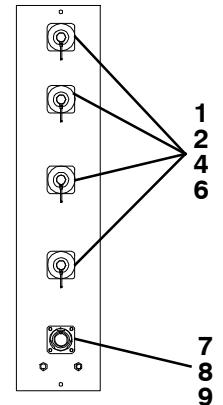

OPTION - V

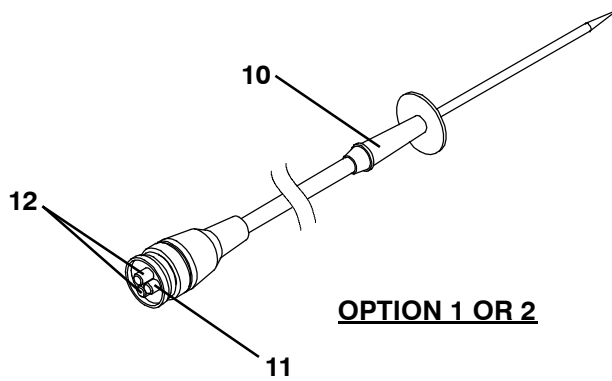

OPTION 1 OR 2

2.21 USDA (Continued)			
Item	Part Number	Description	Qty
OPTION D			
1	22-01660-08	Plug, Sealing	4
2	22-01660-00	Receptacle (PR1, PR2, PR3, Cargo Probe 4) (3 Pin)	4
3	22-01660-03	Receptacle, Interrogator (ICR) (5 Pin)	1
NS	69NT41-992	Plate Assembly, USDA - Includes:	1
4	69NT43-175	Cap, Dust, with Tether (3 Pin)	4
5	69NT43-176	Cap, Dust, with Chain (5 Pin)	1
6	22-01613-14	Contact, Pin, #16 (Used with 22-01660-00 & 22-01660-03)	13
NS	22-01660-04	Plug, Interrogator Socket (ICR) (5 Pin)	1
OPTION V			
1	22-01660-08	Plug, Sealing	4
2	22-01660-00	Receptacle (PR1, PR2, PR3, Cargo Probe 4) (3 Pin)	4
4	69NT43-175	Cap, Dust, with Tether (3 Pin)	4
6	22-01613-14	Contact, Pin, #16 (Used with 22-01660-00 & 22-01660-03)	13
7	22-02412-00	Receptacle, Interrogator (5 Pin)	1
8	22-02413-00	Cap, Dust, with Tether (5 Pin)	1
9	22-02398-02	Socket, Contact (Silver Plated)	A/R
	22-02398-03	Socket, Contact (Gold Plated)	A/R
FIELD INSTALLED KITS (for units with USDA provision)			
-	76-00676-00	Kit, USDA (For field installation, units provisioned for side-mounted USDA) - Includes all of OPTION D.	-

USDA PROBE KITS			
Item	Part Number	Description	Qty
OPTION 1			
10	12-00342-03	Sensor Assembly, 600" Long (15M) (USDA Probe) - Includes:	A/R
11	22-50127-00	Plug, Socket (PR1, PR2, PR3, Cargo Probe 4)	1
12	22-01613-15	Contact, Socket, #16 (Used with 22-50127-00 & 22-01660-04)	A/R
OPTION 2			
10	12-00342-02	Sensor Assembly, 540" Long (13.5M) (USDA Probe) - Includes:	A/R
	12-00342-04	Sensor Assembly, 600" Long (15M) (USDA Probe) - Includes:	A/R
11	22-50127-00	Plug, Socket (PR1, PR2, PR3, Cargo Probe 4)	1
12	22-01613-15	Contact, Socket, #16 (Used with 22-50127-00 & 22-01660-04)	A/R
NOTE			
Do not mix silver pins with gold pins and sockets.			

2.22 BACK PANEL ASSEMBLY - OPTION 1 - ALUMINUM BOLTED

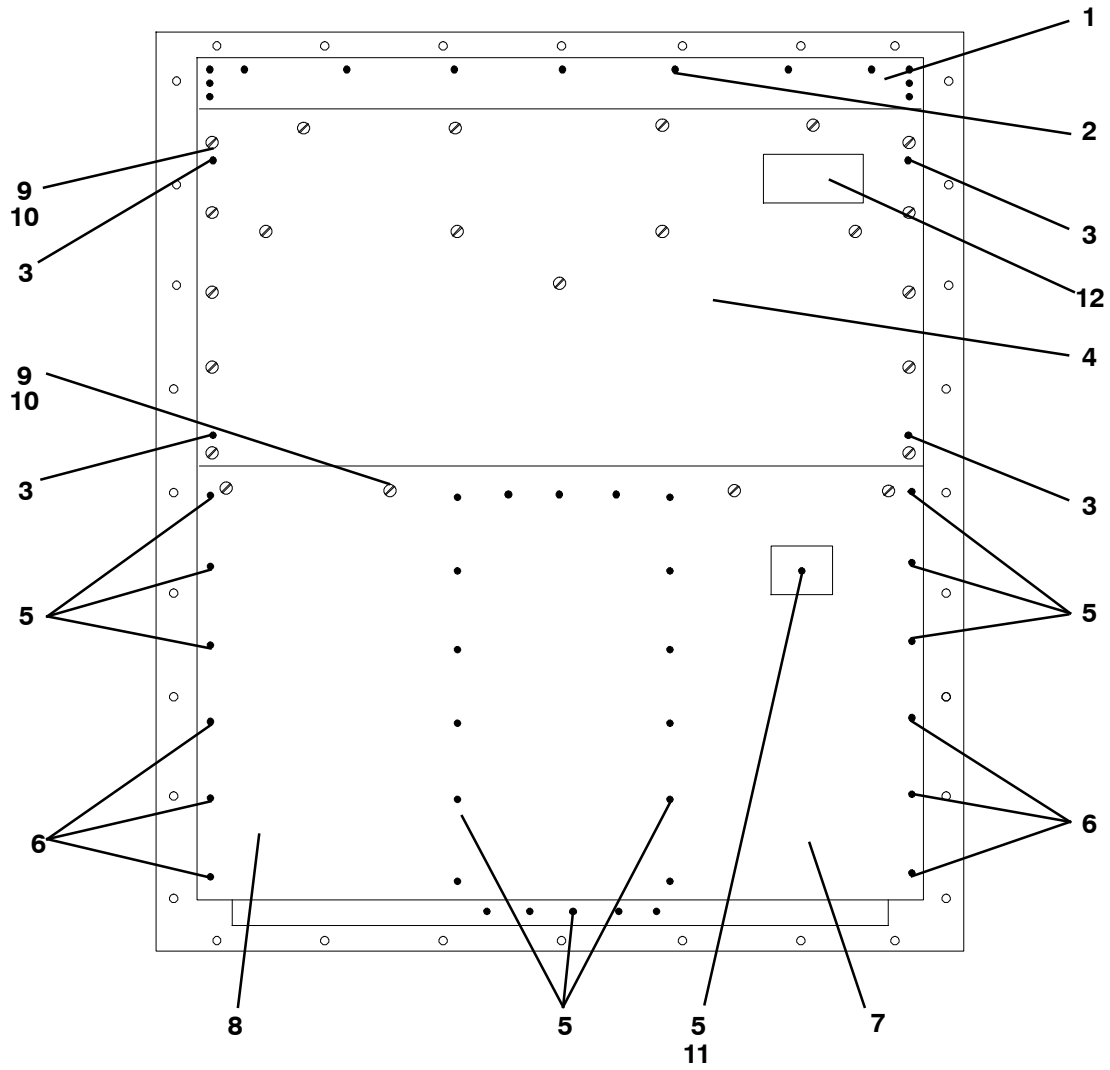

2.22 BACK PANEL ASSEMBLY - OPTION 1 - ALUMINUM BOLTED (Continued)

Item	Part Number	Description	Qty
1	69NT43-464	Grille, Top (Unpainted)	1
2	34-00928-09	Rivet, Blind, 5/32 Diameter, Grip Range - 1/8-1/4	21
3	66U1-7982-2	Rivet, TIR, 3/16 Diameter, Grip Range - 5/64-11/64	4
4	76-00746-05	Panel Assembly, Upper - Includes:	1
NS	68-14038-04	Panel	1
NS	68-15014-00	Drain Pan, Side (Location - Behind upper panel)	1
NS	68-15013-00	Drain Pan, Center (Location - Behind upper panel - Top)	1
NS	58-04624-00	Drain	1
NS	68-14373-00	Plate	1
NS	NSS	Drain Pan (Location - Behind upper panel)	2
NS	42-00334-00	Gasket (Location - Behind upper panel)	1
NS	66U1-8075	Gasket (25 Feet, cut to length)	A/R
5	34-00928-02	Rivet, Blind, 1/8 Diameter, Grip Range - 1/8-3/16	46
6	34-00928-03	Rivet, Blind, 1/8 Diameter, Grip Range - 3/16-1/4	3
7	68-13475-00	Panel, Bottom, (Painted)	1
7	68-13475-08	Panel, Bottom, (Unpainted)	1
8	68-13475-01	Panel, Bottom (Provision for Heat Exchanger location), (Painted)	1
8	68-13475-09	Panel, Bottom (Provision for Heat Exchanger location), (Unpainted)	1
9	66U1-2403	Screw, Machine, Truss Head, #10-24 X 1/2 Long - SST	20
10	69NT35-2692	Washer, Fender, #10 X 1.00 OD - SST	20
11	69NT35-2257	Duct, Air	1
12	62-02822-01	Label, Carrier Transicold	1

2.23 OPTION 7 AND OPTION 8 - ELECTRONIC PARTLOW TEMPERATURE RECORDER

OPTION - 7 and 8

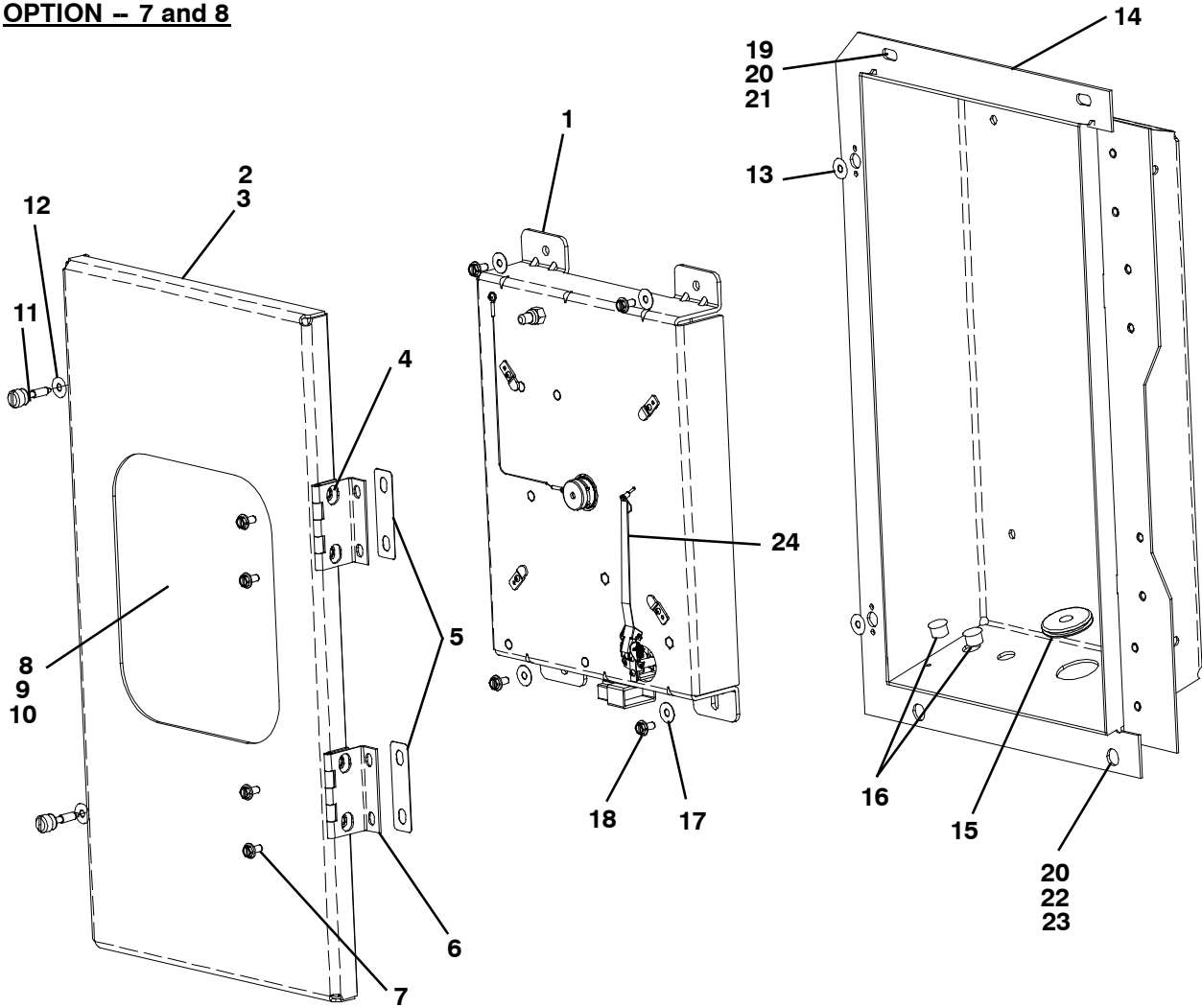

OPTION 9 - NO TEMPERATURE RECORDER

OPTION 9

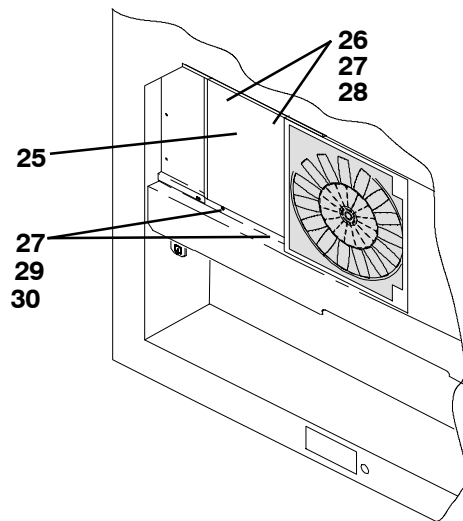

2.23 OPTION 7 AND OPTION 8 - ELECTRONIC PARTLOW TEMPERATURE RECORDER (Continued)

Item	Part Number	Description	Qty
-	76-00701-11 OPTION 7	Partlow Recorder Kit, Standard - Includes: Recorder, Box & Door Assemblies (For field installation, units provisioned for - Refer to online Matrix)	1
1	12-00464-08	Electronic Temperature Recorder	1
-	76-00701-10 OPTION 8	Partlow Recorder Kit, Special - Includes: Recorder, Box & Door Assemblies (For field installation, units provisioned for - Refer to online Matrix)	1
1	12-00464-07	Electronic Temperature Recorder	1
2	76-00701-05	Door Assembly - Includes:	1
3	42-01098-01	Seal, Door - Rubber	1
4	34-06179-04	Screw, HXHD, SEMS, #10-24 X 5/16 Long	4
5	58-04101-07	Protector - Mylar	4
6	44-00374-00	Hinge	2
7	34-06179-00	Screw, HXHD, #10-24 X 7/16 Long - SST	4
8	69NT35-5022-5	Window	1
9	69NT35-5352-1	Gasket	1
10	34-00795-09	Nut, Self-Locking, 1/4-20	4
11	66U1-6811-8	Screw, Retaining - 0.300 - 0.625 Panel Thickness - SST	2
12	34-06053-00	Washer, 0.25 ID X 1.00 OD - Mylar	4
13	34-06169-00	Washer, Retaining - SST	2
14	76-00701-06SV	Box Assembly - Includes:	1
15	58-00065-67	Grommet, 3/8 ID X 1.25 OD	1
16	58-00065-70	Plug, Hole, 0.50 DIA	2
17	34-06053-05	Washer, 1/4 ID X 1 OD - Mylar	4
18	34-06179-00	Screw, HXHD, SEMS, #10-24 X 7/16 Long	4
19	66U1-5321-7	Washer, Flat, 1/4 - SST	2
20	66U1-5361-25	Screw, Cap, HXHD, 1/4-20 X 0.75 Long - SST	4
21	34-06053-13	Washer, Retaining, 0.19 ID X 0.80 OD - Mylar	2
22	69NT35-2692-1	Washer, Fender, 1/4 ID X 0.993-1.015 OD	2
23	34-06053-03	Washer, 0.25 ID X 0.19 OD - Mylar	2
24	09-00371-00	Stylus, Electronic Partlow Kit, Includes:	
NS	-	Chart - Owner Supplied	A/R
NS	09-00128-00	Charts °F - 31 Day (Box of 50) (-20°F to +80°F)	A/R
NS	09-00128-01	Charts °C - 31 Day (Box of 50) (-25°C to +25°C)	A/R

OPTION 9 - NO TEMPERATURE RECORDER

Item	Part Number	Description	Qty
25	68-12658-20	Panel, White	1
	68-12658-04	Panel, Orange	1
26	66U1-5321-7	Washer, Flat, 1/4 - SST	2
27	66U1-5361-25	Screw, Cap HXHD, 1/4-20 X 0.75 Long - SST	4
28	34-06053-13	Washer, Retaining, 0.195 ID X 0.80 OD - Mylar	2
29	69NT35-2692-1	Washer, Fender, 1/4 ID X 0.993-1.015 OD	2
30	34-06053-03	Washer, 0.25 ID X 1.00 OD - Mylar	2

2.24 COMPRESSOR MOUNTING COMPONENTS AND GUARD

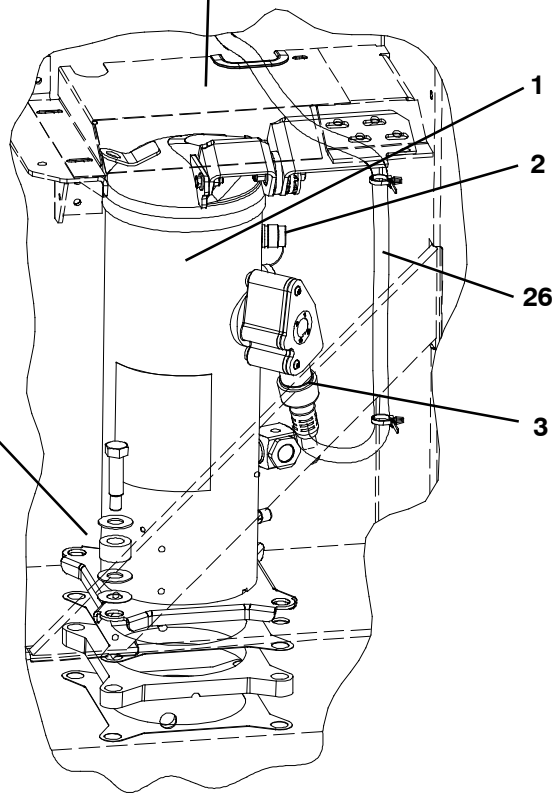
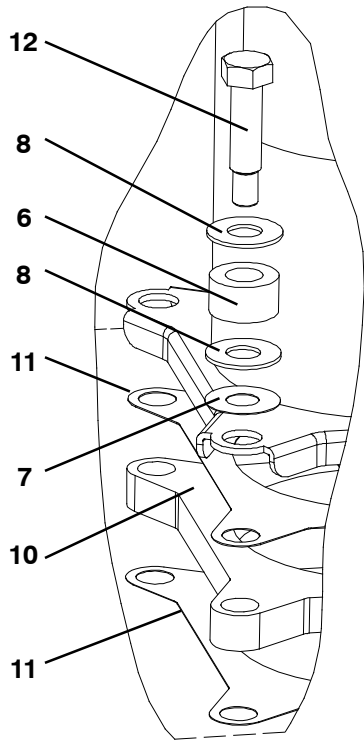
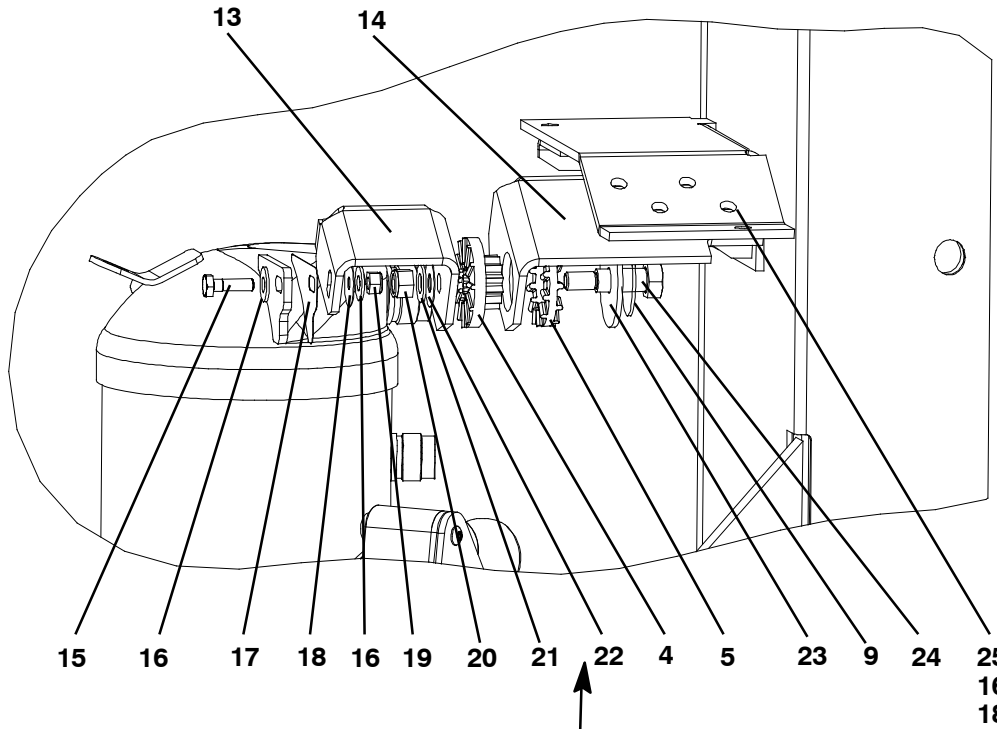

2.24 COMPRESSOR MOUNTING COMPONENTS AND GUARD (Continued)

Item	Part Number	Description	Qty
1	18-10134-23	Compressor, Scroll - Includes: (See Section 4)	-
2	42-00384-01	Seal, Rotolock, 1-14	1
NS	42-00384-02	Seal, Rotolock, 1-1/4-12	2
NS	07-00427-00	Compressor Oil	2
3	18-00077-41	O-Ring	1
4	58-04461-00	Shockmount, Bushing	1
5	58-04461-01	Shockmount, Ring	1
6	58-04451-00	Mount, Resilient, 80A	4
7	34-06053-20	Washer, Mylar - 1.50 X 0.65	4
8	34-06236-00	Washer, 0.687 X 1.50 X 0.078 - SST	8
9	58-04026-62	Protector, Mylar	1
10	48-00350-01SV	Base, Compressor (Painted) - Includes:	1
11	58-04435-00	Protector, Mylar	2
12	34-06174-03	Bolt, Shoulder, 1/2-13 UNC - SST	4
13	86-04406-00	Bracket Assembly	1
14	86-04405-00	Bracket Assembly	1
15	66U1-5361-47	Bolt, Machine HXHD, 1/4-20 X 1.25 Long - SST	1
16	66U1-5321-7	Washer, Plain 1/4 - SST	14
17	58-04463-00	Protector, Mylar	1
18	34-06053-00	Washer, Mylar 0.250 ID X 0.800 OD	9
19	34-00667-11	Nut, Self Lock 1/4-20 - SST	2
20	34-00667-13	Nut, Self Lock 3/8-16 - SST	1
21	66U1-5321-5	Washer, Plain 3/8 N Type A - SST	1
22	34-06053-02	Washer, Mylar 0.375 ID X 1.00 OD	1
23	34-06060-03	Washer, Snubbing 0.537 ID X 2.00 OD	1
24	34-06174-04	Bolt, Shoulder, 3/8-16 UNC - SST	1
25	34-00655-04	Screw, Cap HXHD 1/4-20 X 0.50 - SST	4
26	22-04040-00	Cable, Power	1
NS	68-15150-00	Cover, Compressor	1

2.24 COMPRESSOR MOUNTING COMPONENTS AND GUARDS (Continued)

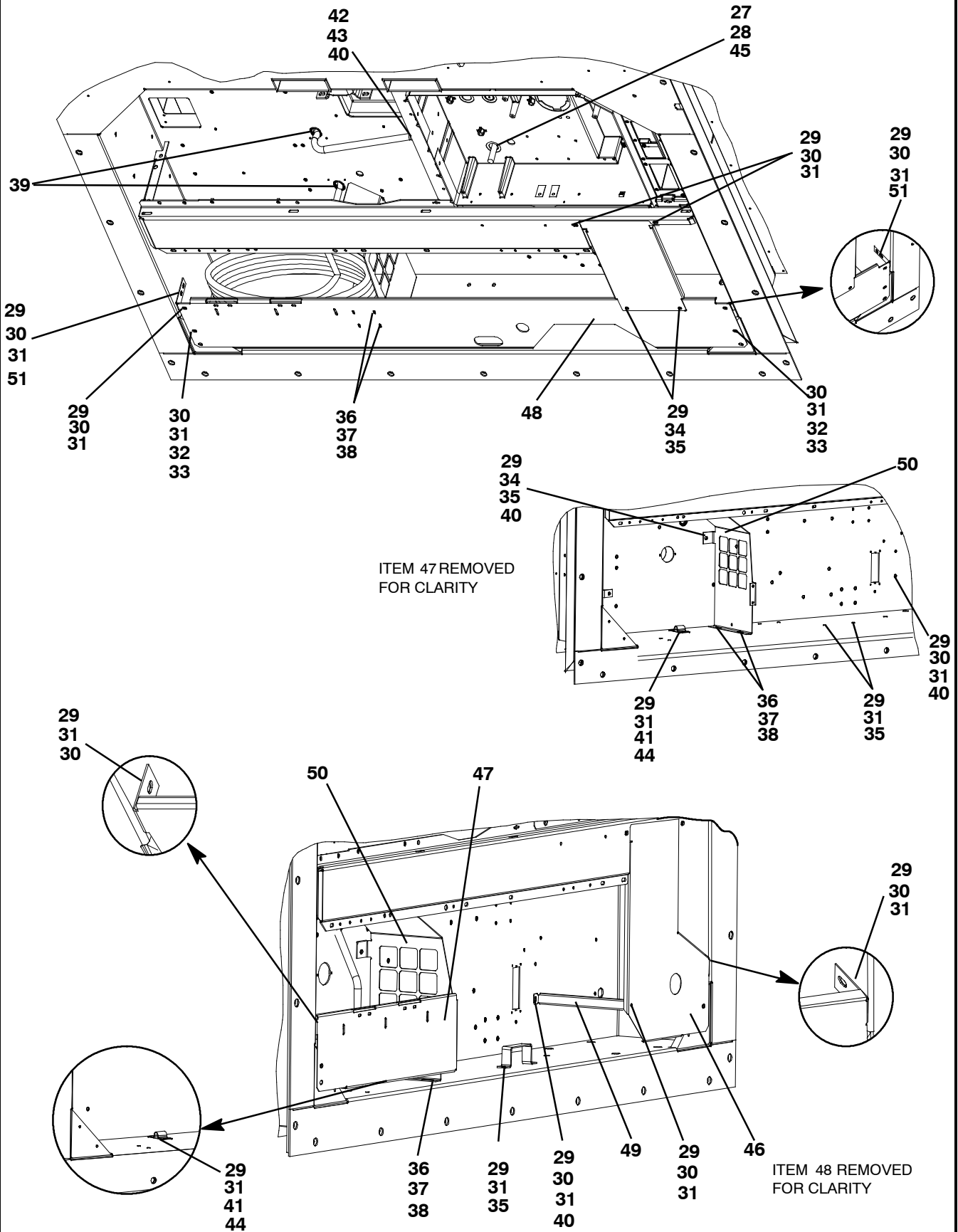

2.24 COMPRESSOR MOUNTING COMPONENTS AND GUARDS (Continued)

Item	Part Number	Description	Qty
STANDARD PARTS INCLUDED IN ALL 77-01191 KITS			
-	77-01191-xx	Standard Parts Included in the Service Kits Include:	1
27	34-06136-01	Nut, Lock, 3/4" NPT	1
28	66U1-1251-2	O-Ring, 3/4 Hub Sealing	1
29	66U1-5361-25	Screw, Cap, HXHD 1/4-20 x 0.75	11
30	34-06053-00	Washer, 0.250 ID x 0.800 OD	9
31	66U1-5321-7	Washer, Plain 1/4 W Type A	14
32	66U1-5361-11	Screw, Cap, HXHD 1/4-20 x 1.50	2
33	34-00667-11	Nut, Self Lock 1/4-20	2
34	69NT35-2692-1	Washer, Fender 1/4-0.993-1.015 OD	1
35	34-06053-03	Washer, 0.250 ID x 1.000 OD	3
36	66U1-5371-6	Screw, Mach, HXHD #10-24 x 0.750 Slotted	2
37	66U1-5321-8	Washer, Plain #10 Type A	2
38	34-06053-05	Washer 0.205 ID x 0.600 OD	2
39	PF-01-24	Sealer, Mastic, 3 Linear. Feet	1
40	PF-20-21	Sealer, Clear, Silicone, 0.0080 gal.	1
41	58-04026-07	Protector, 1.63 x 3.00 Long	1
42	58-04316-00	Base, Mounting, 0.250 Diameter Mtg Hole	1
43	66U1-3882	Wire Tie, 1/16-1-3/4 Self Lock	1
OPTION 1 - STANDARD CABLE WITH RECEIVER OPTION			
SEE ABOVE FOR STANDARD PARTS INCLUDED IN THE KIT AND USE WITH ITEMS BELOW:			
-	77-01191-00	Standard Cable with Receiver Option Includes:	1
44	68-14456-00	Cable Clamp, Cable Cutter 16 Gage	1
45	66U1-7352	Connector, Straight, Watertight	1
46	68-15105-00	Cover, 0.063 Thick Aluminum	1
47	68-15106-00	Guard, 0.080 Thick Alum	1
48	68-15109-00	Guard, 0.125 Thick Alum	1
49	68-15118-00	Brace, Support 0.06 Thick Alum	1
OPTION 2 - STANDARD CABLE WITH FULL GUARD			
SEE ABOVE FOR STANDARD PARTS INCLUDED IN THE KIT AND USE WITH ITEMS BELOW:			
-	77-01191-02	Standard Cable with Full Guard Includes:	1
44	66U1-7352	Connector, Straight, Watertight	1
45	68-14456-00	Cable Clamp, Cable Cutter 16 Gage	1
46	68-15150-00	Cover, 0.063 Thick Alum	1
48	68-14706-01	Guard, 0.125 Thick Alum	1
50	68-15149-00	Partition, 0.90 Thick Alum	1
51	68-14143-00	Bracket 0.125 Thick Alum	2
OPTION 3 - TRANSICORD WITH FULL GUARD			
SEE ABOVE FOR STANDARD PARTS INCLUDED IN THE KIT AND USE WITH ITEMS BELOW:			
-	77-01191-04	Transicord with Full Guard Includes:	1
44	66U1-7352	Connector, Straight, Watertight	1
45	68-14456-00	Cable Clamp, Cable Cutter 16 Gage	1
46	68-15105-00	Cover, 0.063 Thick Alum	1
48	68-14706-01	Guard, 0.125 Thick	1
49	68-15118-00	Brace, Support 0.06 Thick Alum	1

2.24 COMPRESSOR MOUNTING COMPONENTS AND GUARDS (Continued)

Item	Part Number	Description	Qty
OPTION 4 - TRANSICORD WITHOUT RECEIVER OPTION			
SEE PREVIOUS PAGE FOR STANDARD PARTS INCLUDED IN THE KIT AND USE WITH ITEMS BELOW:			
-	77-01191-05	Transicord without Receiver Option Includes:	1
44	66U1-7352-3	Connector, Straight, Watertight	1
45	68-14456-01	Cable Clamp, Cable Cutter 16 Gage	1
46	68-15105-00	Cover, 0.063 Thick Alum	1
47	68-15106-00	Guard, 0.080 Thick Alum	1
49	68-15118-00	Brace, Support 0.06 Thick Alum	1
OPTION 5 - STANDARD CABLE WITH RECEIVER OPTION, ORANGE			
SEE PREVIOUS PAGE FOR STANDARD PARTS INCLUDED IN THE KIT AND USE WITH ITEMS BELOW:			
-	77-01191-06	Standard Cable with Receiver Option Includes:	1
44	66U1-7352	Connector, Straight, Watertight	1
45	68-14456-00	Cable Clamp, Cable Cutter 16 Gage	1
46	68-15105-01	Cover, 0.063 Thick Alum, Orange	1
47	68-15106-01	Guard, 0.080 Thick Alum, Orange	1
48	68-15109-01	Guard, 0.125 Thick Alum, Orange	1
49	68-15118-01	Brace, Support, 0.06 Thick Alum, Orange	1

2.25 TRANSDUCERS

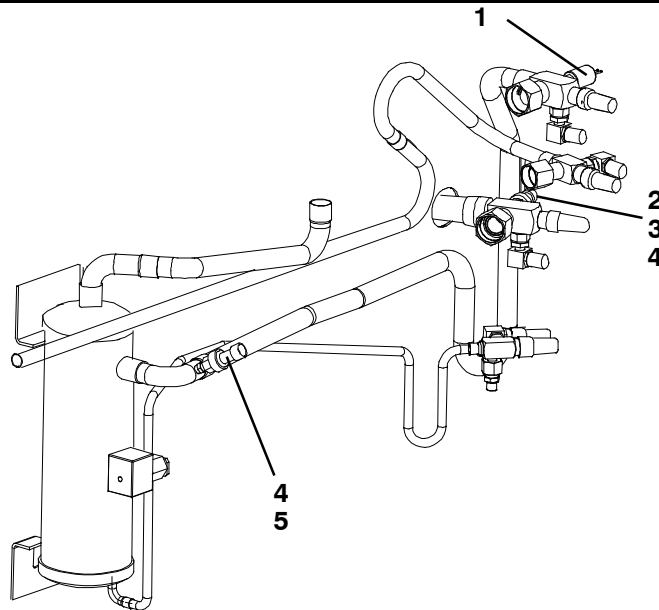

Option T - Transducer Locations

Item	Part Number	Description	Qty
OPTION T - PRESSURE TRANSDUCERS			
1	12-00309-05	Switch, Pressure	1
-	12-00352-07SV	Transducer Kit - Includes:	1
2	12-00352-07	Transducer, Suction NSS	1
3	22-01713-12	Cable, SPT Patch	1
4	EC39DM070	Core, Check Valve (Used with 40-00604-00 Tee)	3
5	12-00352-00	Transducer, Discharge	1

2.26 CABLE RESTRAINT COMPONENTS

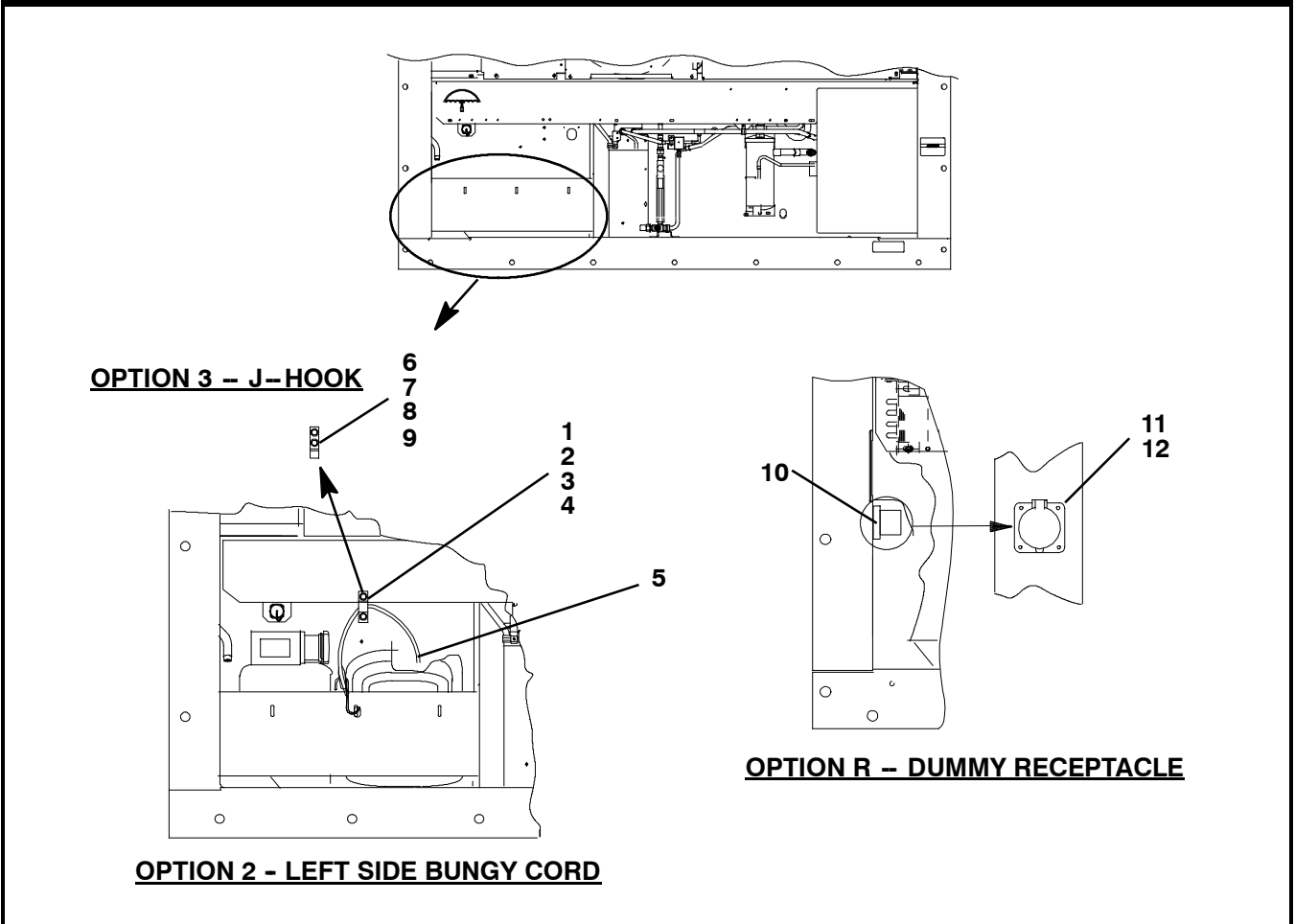

Item	Part Number	Description	Qty
OPTION 2 - LEFT BUNGY CORD ONLY			
1	69NT35-5992	Cable Restraint	1
2	66U1-5321-7	Washer, Flat, 1/4 - SST	2
3	66U1-5361-25	Screw, Cap, Hex, Head, 1/4-20 X 0.75 lg - SST	2
4	34-06053-03	Washer, Mylar, 0.25 ID X 1.00 OD	2
5	66U1-2603	Strap, Tie Down	1
OPTION 3 - J-HOOK			
6	69NT35-8382	Cable Restraint, J-Hook	1
7	58-04026-22	Protector, Mylar	1
8	66U1-5321-7	Washer, Flat, 1/4 - SST	2
9	66U1-5361-25	Screw, Cap, Hex, Head, 1/4-20 X 0.75 lg - SST	2
OPTION R - DUMMY RECEPTACLE			
10	22-01679-03	Receptacle	1
11	66U1-5321-8	Washer, Flat, #10 SST	4
12	66U1-5371-6	Screw, Cap, Hex, Head, 10-24 X 0.75 lg - SST	4

2.27 VOLTAGE CABLES

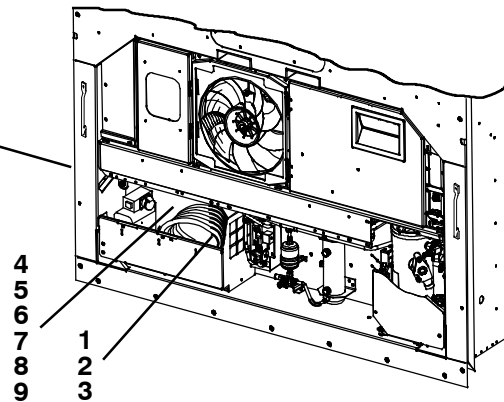
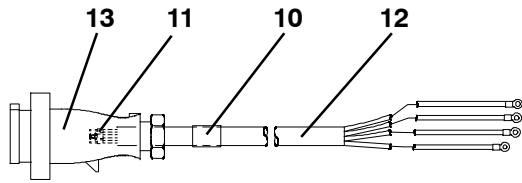

Item	Part Number	Description	Qty
CLAMPS ON BACK WALL AND CABLE CUTTERS			
1	34-00373-56	Clamp, Tube, Cushioned, 9/16 Diameter (Used with Transicord)	A/R
	34-00373-59	Clamp, Tube, Cushioned, 3/4 Diameter	A/R
2	66U1-5381-1	Screw, HXHD, #10-24 X 3/4 Long - SST	A/R
3	34-06053-03	Washer, Mylar, 1/4 ID X 1.00 OD	A/R
4	69NT35-6412-2	Clamp, Cable Cutter, 8 AWG cable	1
	68-14456-00	Clamp, Cable Cutter, 10 AWG cable	1
	68-14456-01	Clamp, Cable Cutter, 11 AWG cable	1
5	58-04026-07	Protector, Mylar	A/R
6	66U1-5361-11	Screw, Machined HXHD, 1/4-20 X 1-1/2 Long - SST	A/R
7	34-00667-11	Locknut, HXHD, 1/4-20 - SST	A/R
8	66U1-5321-7	Washer, Flat, 1/4 - SST	A/R
9	34-06053-03	Washer, Mylar, 0.25 ID X 1.00 O. D.	A/R
460V CABLES			
STANDARD PARTS FOR ALL 460V CABLES			
10	66U1-2583	Heat Shrink Tube (Coil Label) - "460V"	1
11	22-02324-01	Bushing (Used with Standard Cable)	4
	22-02324-05	Bushing (Used with Transicord)	4
OPTION 1			
12	66U1-9782	Cable, Power - Yellow, 10/4	A/R
13	22-02378-00	Plug, Power	1
OPTION 2			
12	22-01551-00	Cable, Power - Yellow, 33 Amp, 11 AWG	A/R
13	22-02378-00	Plug, Power	1
OPTION 3			
12	66U1-9782	Cable, Power - Yellow, 10/4	A/R
13	22-01891-00	Plug, Power	1
OPTION 4			
12	22-01551-00	Cable, Power - Yellow, 33 Amp, 11 AWG	A/R
13	22-01891-00	Plug, Power	1

2.27 VOLTAGE CABLES (Continued)			
Item	Part Number	Description	Qty
OPTION 5			
12	22-01551-00	Cable, Power - Yellow, 33 Amp, 11 AWG	A/R
13	22-01883-00	Plug, Power	1
OPTION 6			
12	22-01551-00	Cable, Power - Yellow, 33 Amp, 11 AWG	A/R
13	22-01891-00	Plug, Power	1
OPTION 7			
12	66U1-9782	Cable, Power - Yellow, 10/4	A/R
13	22-01891-00	Plug, Power	1
OPTION 8			
12	66U1-9782	Cable, Power - Yellow, 10/4	A/R
13	22-01932-00	Plug, Power	1
OPTION 9			
12	66U1-9782	Cable, Power - Yellow, 10/4	A/R
13	22-02232-00	Plug, Power	1
230V CABLES			
STANDARD PARTS FOR ALL 230V CABLES			
10	66U1-2583-1	Heat Shrink Tube (Coil Label) - "230V"	1
11	22-02324-02	Bushing (Used with 8 AWG)	4
12	66U1-9782-1	Cable, Power - Black, 35 amps, 8 AWG	A/R
OPTION 1			
13	22-02188-00	Plug, Power	1
OPTION 2			
13	22-02375-00	Plug, Power	1
OPTION 3			
13	66U1-6782-3	Plug, Power	1
OPTION 4			
13	22-01744-00	Plug, Power	1
OPTION 5			
13	22-02322-00	Plug, Power	1
OPTION 6			
13	22-01884-00	Plug, Power	1
OPTION 7			
13	66U1-6782	Plug, Power	1
OPTION 8			
13	22-01931-00	Plug, Power	1
OPTION 9			
13	22-01906-00	Plug, Power	1

2.28 AUTOTRANSFORMER KIT

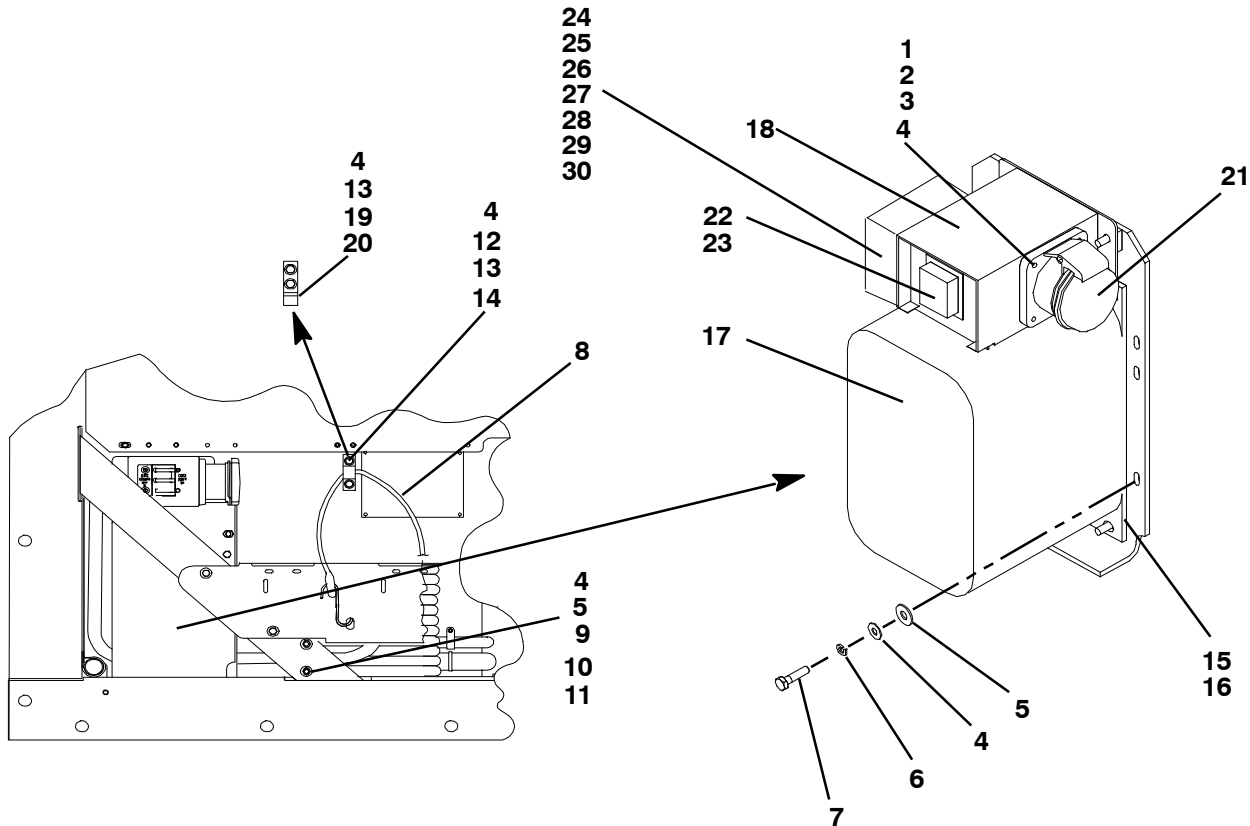

Item	Part Number	Description	Qty
STANDARD PARTS INCLUDED IN EVERY 76-00670 SERVICE KIT			
-	76-00670-Xx	Standard Parts Included in the Service Kits Include:	1
1	66U1-5371-7	Screw, HXHD, #10-24 X 1/2 Long - SST	4
2	66U1-5321-8	Washer, Flat, #10 - SST	4
3	34-06053-05	Washer, Mylar, 0.205 ID X 0.600 OD	4
4	66U1-5321-7	Washer, Flat, 1/4 - SST	A/R
5	34-06053-00	Washer, Mylar, 0.250 ID X 0.800 OD	5
6	AU11JR171	Washer, Lock, 1/4 - SST	5
7	AA06JA170	Screw, HXHD, 1/4-20 X 1.00 Long	5
8	66U1-2603	Strap, Tie Down	1
9	58-04026-07	Protector, Mylar	1
10	66U1-5361-11	Screw, Machined HXHD, 1/4-20 X 1-1/2 Long - SST	2
11	34-00667-11	Locknut, HXHD, 1/4-20 - SST	2
12	69NT35-5992	Clamp, Tie Down Strap	1
13	66U1-5361-25	Bolt, HXHD, 1/4-20 X 3/4 Long - SST	A/R
14	34-06053-03	Washer, Mylar, 0.25 ID X 1.00 OD	2
15	69NT43-374	Bracket Assembly	1
16	58-04026-17	Protector, Mylar	1

2.28 AUTOTRANSFORMER KIT (Continued)

Item	Part Number	Description	Qty
OPTION 1 - AUTOTRANSFORMER			
See Previous Page for Standard Parts Included in the Kit and use with Items Below			
-	76-00670-02	Transformer Kit, Field Installation, without CB2 - Includes:	1
17	10-01139-04	Transformer, Dual Voltage Modular	1
NS	22-01778-00	Terminal Block - Used only without CB2	1
18	69NT43-470-1	Box Assembly	1
19	69NT35-8382	Clamp, Tie Down Strap	1
20	58-04026-22	Protector, Mylar	1
OPTION 2 - AUTOTRANSFORMER WITH CB2 AND RECEPTACLE			
See Previous Page for Standard Parts Included in the Kit and use with Items Below			
-	76-00670-01	Transformer Kit, Field Installation, with CB2 - Includes:	1
17	10-01139-04	Transformer, Dual Voltage Modular	1
18	69NT43-470	Box Assembly - Used only with CB2	1
21	22-01679-00	Receptacle - 32 Amp	1
	22-01679-01	Receptacle w/ Screw Cap - 32 Amp, Alternate, SOLD SEPARATELY	1
19	69NT35-8382	Clamp, Tie Down Strap	1
20	58-04026-22	Protector, Mylar	1
-	76-00667-05	Circuit Breaker Kit, Field Installation - Includes:	1
22	10-00083-05	Circuit Breaker, 70 Amp - 250 vac, 50/60 hz	1
23	66U2-1531	Boot - Includes:	1
NS	NSS	Frame	1
NS	NSS	Screw, Self Sealing, #6-32 X 3/8 Long - SST	6
OPTION 3 - AUTOTRANSFORMER WITH CB2 AND BRIDGING UNIT			
See Previous Page for Standard Parts Included in the Kit and use with Items Below			
-	76-00670-03	Transformer Kit, Field Installation, with CB2 and TBU - Includes:	1
17	10-01139-04	Transformer, Dual Voltage Modular	1
18	69NT43-470-2	Box Assembly	1
19	69NT35-8382	Clamp, Tie Down Strap	1
20	58-04026-22	Protector, Mylar	1
-	76-00667-05	Circuit Breaker Kit, Field Installation - Includes:	1
22	10-00083-05	Circuit Breaker, 70 amp - 250 vac, 50/60 hz	1
23	66U2-1531	Boot - Includes:	1
NS	NSS	Frame	1
NS	NSS	Screw, Self Sealing, #6-32 X 3/8 Long - SST	6
24	12-00474-00	Bridge Unit, Transformer	1
25	42-00470-00	Gasket, Transformer Bridge Unit	1
26	34-06221-00	Screw, HXHD, #10-24 X 2.50 Long - SST	2
27	34-00667-09	Locknut, HXHD, #10-24 - SST	2
28	66U1-5321-8	Washer, Flat #10 - SST	2
29	34-06053-05	Washer, Mylar 0.205 ID X 0.600 OD	2
30	22-02324-01	Bushing, 0.142 ID X 0.472 OD	3
OPTION 4 - AUTOTRANSFORMER WITH CB2 AND RECEPTACLE			
See Previous Page for Standard Parts Included in the Kit and use with Items Below			
-	76-00670-04	Transformer Kit, Field Installation, with CB2 - Includes: Everything in kit 76-00670-01 except replace item #22 with below	1
21	22-01734-01	Receptacle - 32 Amp	1

2.29 LABELS AND DECALS (Not Applicable to All Units)

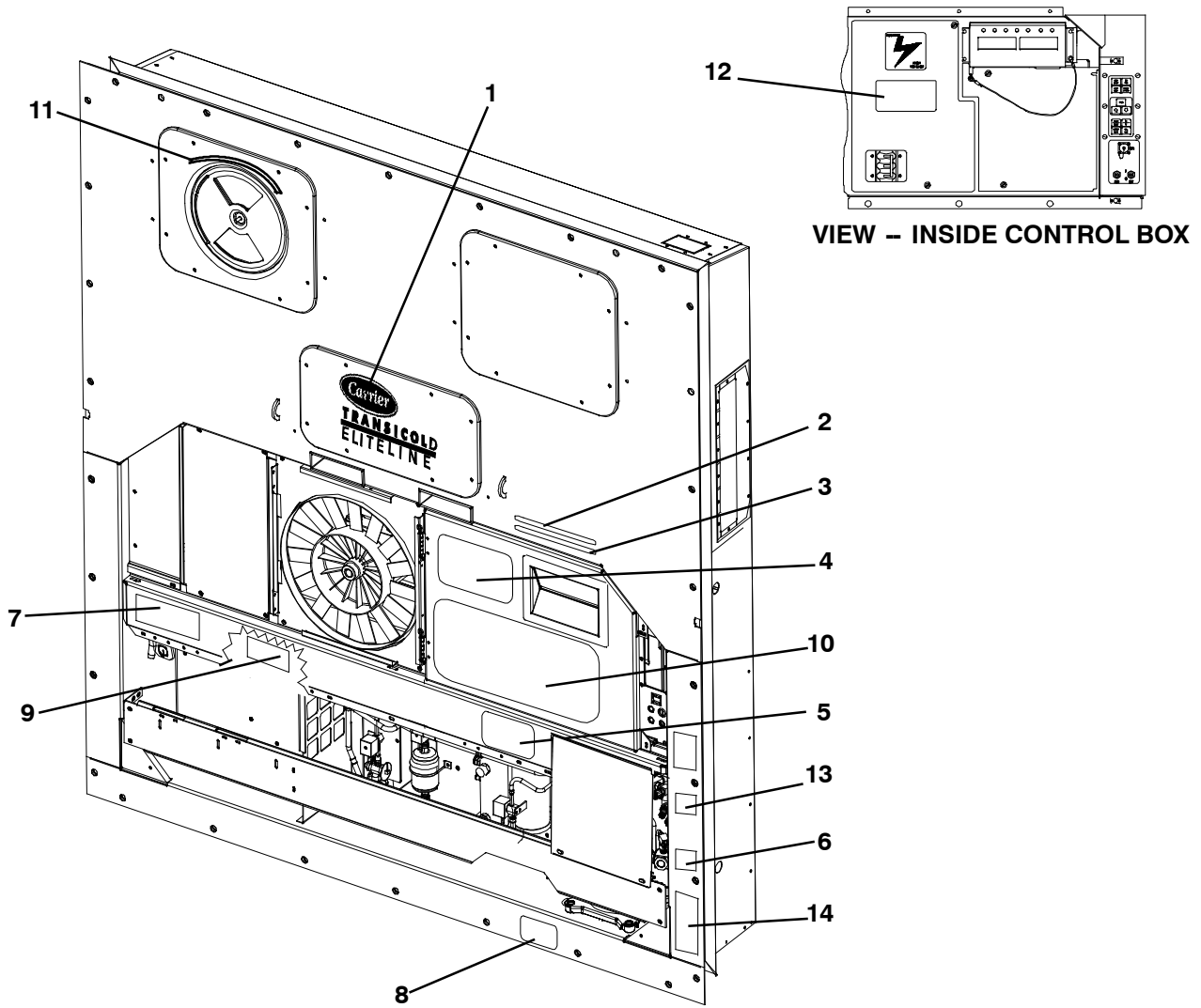

Item	Part Number	Description	Qty
STANDARD LABELS			
1	62-10754-00	Decal, Carrier EliteLine	1
2	69NT35-3867	Label, Economy Mode	1
3	69NT35-3907	Label, Humidity Control Sensor	1
4	62-02721-07	Label, Function Code - <i>English</i>	1
5	62-10902-02	Label, USDA Cold Certified	1
	62-10902-03	Label, Micro-Link 3 with USDA Cold Certified	1
	62-10902-04	Label, Micro-Link 3 without USDA Cold Certified	1
6	62-02444-01	Label, Charge with R-134a	1
7	62-10259-00	Label, R-134a - Ozone Protection - <i>English</i>	1
	62-02530-01	Label, R-134a - Ozone Protection, Umbrella Only - <i>English</i>	1
8	62-02458-01	Label, POE Compressor Oil	1
9	62-02785-00	Label, CE	1
NS	69NT35-6118	Label, USDA (Location - Back of Unit, top left side)	1

2.29 LABELS AND DECALS (Continued)

Item	Part Number	Description	Qty
OPTION 1 - ENGLISH			
10	62-02743-16	Label, Operating Instructions (Electronic Partlow w/ Supply & Return Air)	1
	62-02743-18	Label, Operating Instructions (No Recorder)	1
11	62-02723-00	Label, Fresh Air Makeup - <i>English</i>	1
	62-02723-03	Label, Fresh Air Makeup (w/ Full CMH) - <i>English</i>	1
	62-02723-10	Label, Fresh Air Makeup (w/ Full CMH + CFM) - <i>English</i>	1
12	62-10532-00	Label, Welding Precautions - <i>English</i>	1
13	62-10766-00	Label, Compressor Removal - <i>English</i>	1
14	62-10717-00	Label, Warning Compressor Power-Up - <i>English</i>	1
OPTION 2 - ENGLISH/SPANISH			
10	62-02743-01	Label, Operating Instructions (Partlow w/ Return Air) - <i>English/Spanish</i>	1
	62-02743-10	Label, Operating Instructions (No Recorder)- <i>English/Spanish</i>	1
11	62-02723-02	Label, Fresh Air Makeup - <i>English/Spanish</i>	1
	62-02723-04	Label, Fresh Air Makeup (w/ Full CMH) - <i>English/Spanish</i>	1
12	62-10532-02	Label, Welding Precautions - <i>English/Spanish</i>	1
13	62-10532-00	Label, Compressor Removal - <i>English/Spanish</i>	1
14	62-10532-00	Label, Warning Compressor Power-Up - <i>English/Spanish</i>	1
OPTION 5 - ENGLISH/TRADITIONAL CHINESE			
10	62-02743-19	Label, Operating Instructions (Electronic Partlow w/ Supply & Return Air) - <i>English/Chinese</i>	1
11	62-02723-06	Label, Fresh Air Makeup - <i>English/Chinese</i>	1
12	62-10532-04	Label, Welding Precautions - <i>English/Chinese</i>	1
13	62-10532-00	Label, Compressor Removal - <i>English</i>	1
14	62-10532-00	Label, Warning Compressor Power-Up - <i>English</i>	1

3 INTERROGATOR AND ACCESSORIES

3.1 DATAVIEW/DATAREADER

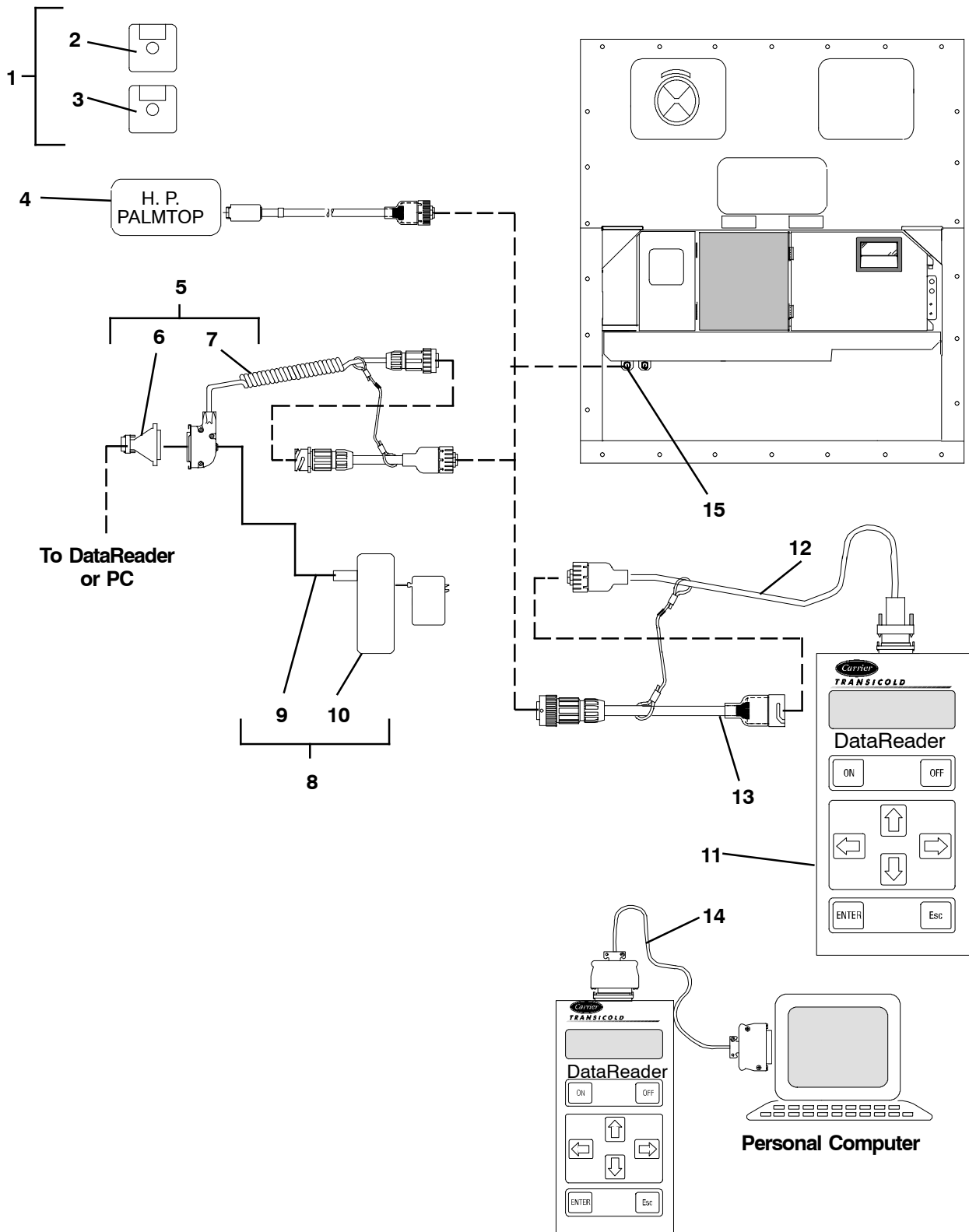

3.1 DATAVIEW/DATAREADER (Continued)

Item	Part Number	Description	Qty
1	07-00406-00	Disk Kit, DataView (SEE NOTE) - Includes:	1
2	12-00413-05SV	Software, DataView NSS	1
3	12-00528-00	Software, DataView (Scroll) NSS	1
4	22-01737-02	Cable, H. P. Palmtop	1
5	76-50059-00	Kit, Cable, with Adapter - Includes:	1
6	22-02418-02	Cable, Interrogator	1
7	22-02420-00	Adapter	1
8	76-50058-00	Kit, Battery, with Cable - Includes:	1
9	NSS	Battery, External, with Battery Charger	1
10	22-02401-00	Cable	1
11	No Longer Offered	DataReader	-
12	22-01737-00	Cable, Download	1
13	22-01737-01	Cable, Adapter	1
14	22-01743-00	Cable, Upload	1
15	-	Receptacle - Refer to Section 3.2	-

NOTE

Kit includes a 3.5 DS/HD Diskette, Formatted. If a DS/DD Diskette is required, contact a Customer Service Representative.

3.2 INTERROGATOR RECEPTACLE

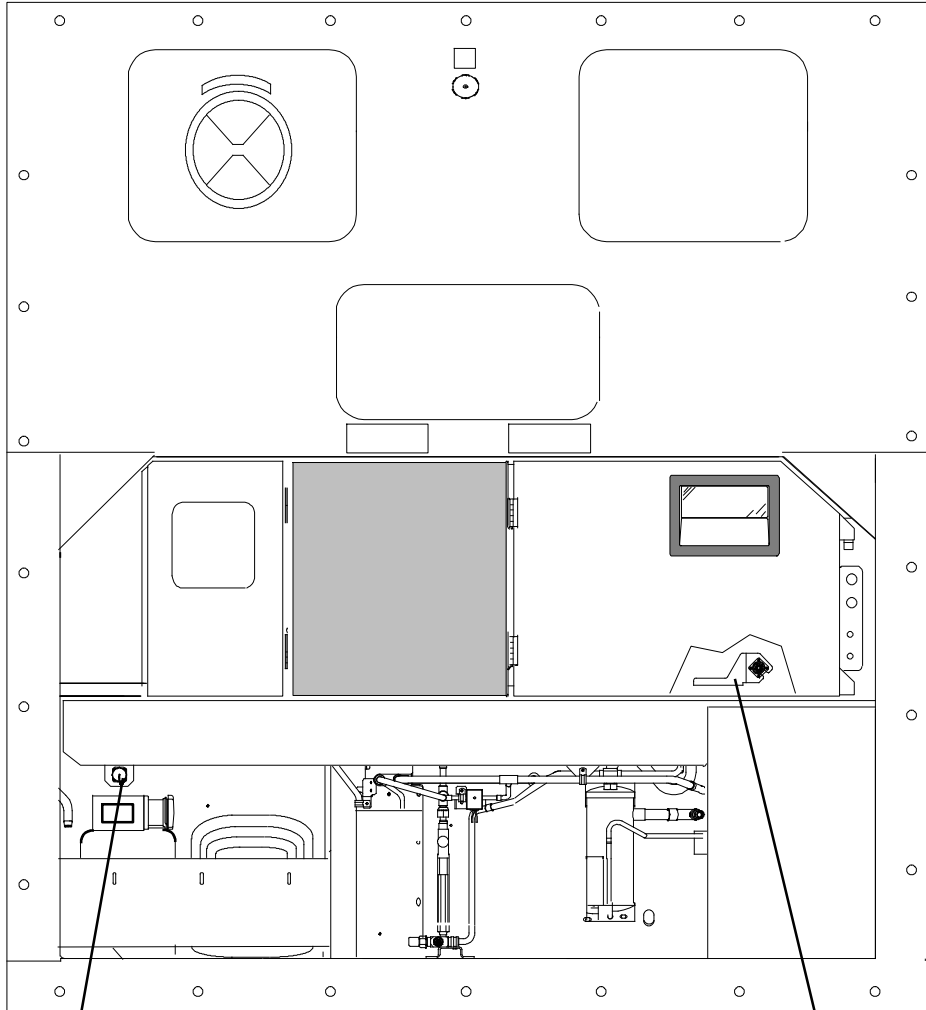

OPTION 1, OPTION 4 and OPTION 5

- | | | |
|----------|-----------|-----------|
| 1 | 9 | 13 |
| 2 | 10 | 14 |
| 3 | 11 | 15 |
| 4 | 12 | 16 |

OPTION 3

- | |
|----------|
| 5 |
| 6 |
| 7 |
| 8 |

3.2 INTERROGATOR RECEPTACLE (Continued)

Item	Part Number	Description	Qty
OPTION 1 - LEFT STRAIGHT MOUNT			
1	22-01660-03	Receptacle, Interrogator (ICR) (5 Pin)	1
2	22-01613-14	Contact, Pin, #16	5
3	69NT43-176	Cap, Dust, with Tether (5 Pin)	1
4	69NT41-192	Bracket, Interrogator Connector	1
OPTION 3 - BOX MOUNT			
5	22-01660-03	Receptacle, Interrogator (ICR) (5 Pin)	1
6	22-01613-14	Contact, Pin, #16	5
7	68-12434-02	Bracket, Interrogator Connector	1
8	42-00174-38	Gasket, Interrogator Connector Bracket	1
OPTION 4 - LEFT STRAIGHT MOUNT			
9	22-02412-00	Receptacle, Interrogator (ICR) (5 Pin)	1
10	22-02412-02	Contact, Pin, #16	5
11	22-02413-00	Cap, Dust, with Tether (5 Pin)	1
12	69NT40-222	Bracket, Interrogator Connector	1
OPTION 5 - LEFT ANGLED MOUNT			
13	22-01660-03	Receptacle, Interrogator (ICR) (5 Pin)	1
14	22-01613-14	Contact, Pin, #16	5
15	69NT43-176	Cap, Dust, with Tether (5 Pin)	1
16	68-12553-00	Bracket, Interrogator Connector	1

NOTE

Do not mix silver and gold pins and sockets.

4 COMPRESSOR

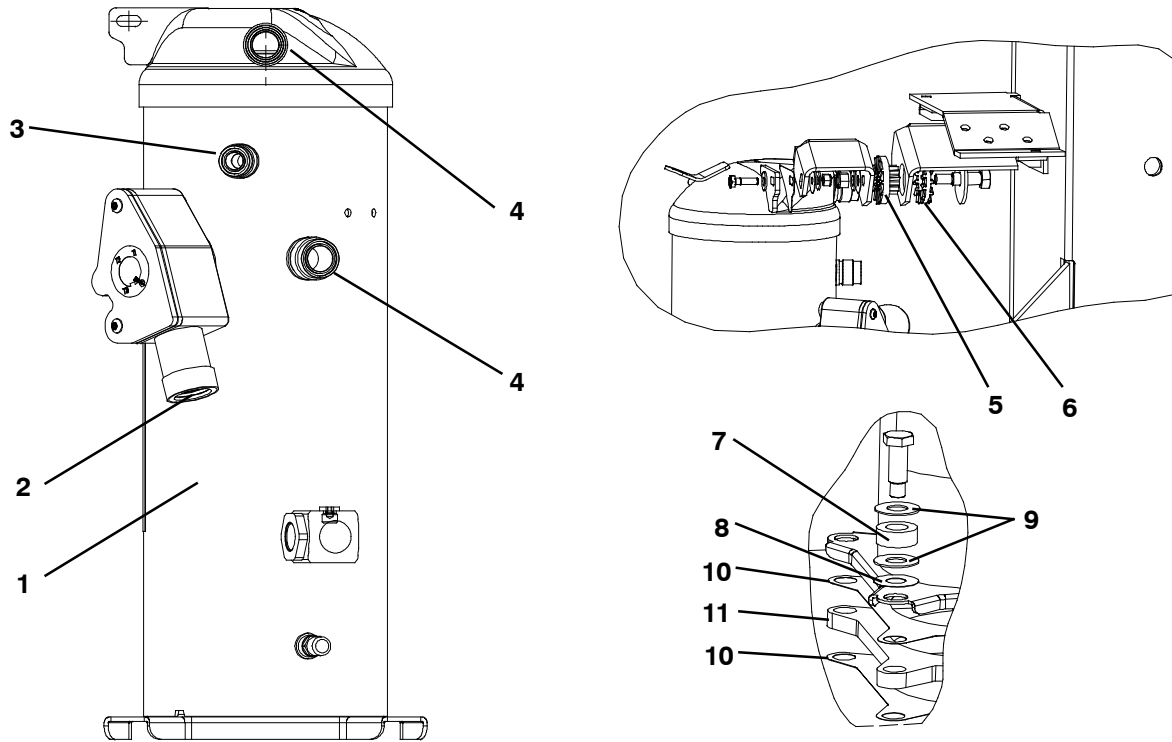

Item	Part Number	Description	Qty
1	18-10134-21	Compressor, Scroll (See Section 2.24) - Includes:	1
2	18-00077-41	O-Ring	1
3	42-00384-01	Seal, Rotolock, 1-14	1
4	42-00384-02	Seal, Rotolock, 1-1/4-12	2
5	58-04461-00	Shockmount, Bushing	1
6	58-04461-01	Shockmount, Ring	1
7	58-04451-00	Mount, Resilient, 80A	4
8	34-06053-20	Washer, Mylar - 1.50 X 0.65	4
9	34-06236-00	Washer - 0.687 X 1.50 X 0.78	8
10	58-04435-00	Protector, Mylar	2
11	48-00350-01SV	Base, Compressor (Painted)	1
NS	07-00427-00	Compressor Oil (Quart)	2

5 CONTROLLER/DATACORDER CONFIGURATION

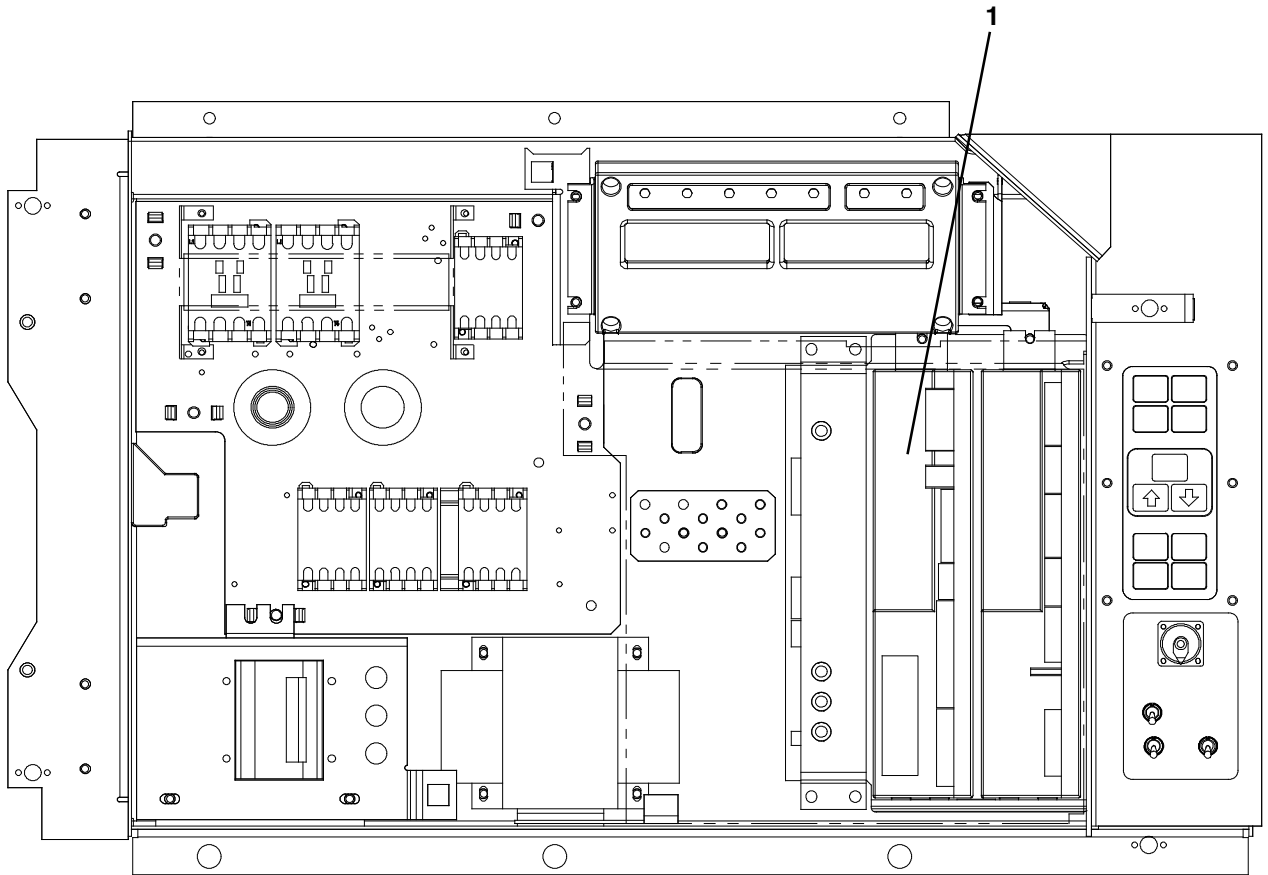

Item	Part Number	Description	Qty
1	12-55009	Controller - Un-Configured (See Note 1)	1
	-	Controller - Configured (See Note 2 and Refer to Container Unit Matrix)	1

NOTES

1. The last four digits of the Part Number refer to the operation software revision.
2. The Controller/DataCORDER module is shipped with the operational software already loaded, however, when ordering this part number the end user must load the configuration software at the time of installation.

6 TOOLS	
PART NO.	DESCRIPTION
07-00013-00	Temperature Tester (Simpson Meter)
07-00013-01	Temperature Test Lead (15 Foot)
07-00013-02	Temperature Test Lead (50 Foot)
07-00013-03	Adapters, Male (Both Ends) (Use with Temperature Tester)
07-00015-00	Case, Carrying (Used with 07-00013-00)
07-00176-11	Vacuum Pump, Dual Voltage/Dual Frequency
07-00375-00	Stepper Motor Drive Tester
07-00450-00	Wrench, Compressor Sight Glass
07-00437-00	Inspection Light with Mirror
07-00228-00	Volt-Ohmmeter, Digital
07-00229-00	Amprobe Clamp (Used with 07-00228-00)
07-00238-00	Wrench, Service Valve
07-00243-10	Multimeter, Digital (Fluke)
07-00263-00	Pliers, Crimping (Used for Compressor Terminal Block replacement)
07-00264-00	Grip, Wire Vise (Used for Compressor Terminal Block replacement)
07-00277-00	Kit, Static Dissipative (Used for working on electronic components)
07-00304-00	Ground Strap, Wrist (Used for working on electronic components)
07-00294-00	Gauge Set, Manifold - Fahrenheit/PSI
07-00294-05	Gauge Set, Manifold - Centigrade/KPa
07-00295-00	Detector, Leak
07-00397-03	Extractor, Pin (Used on Fan Motor Plugs and Interrogator Plugs)
07-00397-02	Crimper, Pin (Used on Fan Motor Plugs and Interrogator Plugs)
07-00329-00	Extractor, Pin (Used on Controller Module Connectors)
07-00330-00	Crimper, Pin (Used on Controller Module Connectors)
07-00370-00	Crimper, Pin (Used on Stepper Valve, HPS)
07-00387-00	Extractor, Pin (Used on Stepper Valve, HPS)
07-00375-00	Tester, Portable, Stepper Motor Drive
07-00391-00	Application Gun (Used with 07-00390-00)
07-00398-00	Software Card Programmer
07-00408-00	Stepper Jumper Assembly
07-00409-00	1-1/8", 3/8" Drive, u/o Economizer Valve
07-00410-00	1-3/8", 3/8" Drive, u/o Suction/Discharge Valve
07-00411-00	2-1/8", 3/8" Drive, u/o SMV
07-00418-00	Torx Driver Bit
Refer to Manual 62-03213	

PART NUMBER INDEX

PART NO.	PAGE NO.	PART NO.	PAGE NO.	PART NO.	PAGE NO.
02-00082-00	9	07-00450-00	58	12-00528-00	53
04-50027-00	27	08-00297-20	33	12-00573-00SV	15
04-50029-00	17	09-00128-00	39	12-00594-xx/5315	13
07-00013-00	58	09-00128-01	39	12-01071-01SV	23
07-00013-01	58	09-00369-00SV	13	12-55009	57
07-00013-02	58	10-00083-05	49	14-00215-05	23
07-00013-03	58	10-00332-21SV	11	14-00220-01	23
07-00015-00	58	10-00366-01SV	11	14-00220-04	22
07-00176-11	58	10-00413-00	33	14-00212-04	25
07-00228-00	58	10-00431-02	11	14-00221-04	22
07-00229-00	58	10-00431-06	10	14-00232-31	25
07-00238-00	58	10-00431-07	10	14-00263-05	33
07-00243-10	58	10-00431-08	10	14-00263-20	33
07-00263-00	58	10-00455-00	31	14-00273-02	33
07-00264-00	58	10-01129-07SV	11	14-00285-00	25
07-00277-00	58	10-01129-10	11	14-00311-02SV	1
07-00294-00	58	10-01139-04	49	14-00341-07	25
07-00294-05	58	10-0298-01	10	14-01032-14	22
07-00295-00	58	12-00275-19SV	15	14-01090-12	25
07-00304-00	58	12-00309-05	44	14-01091-01	22, 23, 25
07-00313-00	1	12-00342-02	35	14-01091-02	33
07-00329-00	58	12-00342-03	35	14-01092-15	23
07-00330-00	58	12-00342-04	35	14-50341-02SV	25
07-00345-00	1	12-00352-00	44	14-00212-14	25
07-00370-00	58	12-00352-07	44	14-00284-20	25
07-00375-00	58	12-00352-07SV	44	14-00341-07PK25	25
07-00387-00	58	12-00395-01SV	26	18-00077-41	41, 56
07-00390-00	9	12-00413-05SV	53	18-10134-21	56
07-00391-00	9, 58	12-00433-00RP	15	18-10134-23	41
07-00397-02	58	12-00433-02RP	15	22-00041-00	1
07-00397-03	58	12-00464-07	39	22-00041-02	1
07-00398-00	58	12-00464-08	39	22-00066-01	1
07-00406-00	53	12-00474-00	49	22-00066-02	1
07-00408-00	58	12-00493-06	33	22-00066-03	1
07-00409-00	58	12-00493-08	21	22-00119-04	1
07-00410-00	58	12-00493-09	33	22-00120-04	1
07-00411-00	58	12-00495-02SV	22, 23	22-00120-07	1
07-00418-00	58	12-00495-20SV	33	22-00121-07	1
07-00427-00	41, 56	12-00500-01SV	33	22-00595-01	1
07-00437-00	58				

PART NUMBER INDEX

PART NO.	PAGE NO.	PART NO.	PAGE NO.	PART NO.	PAGE NO.
22-01106-00	1	22-01743-00	53	22-02412-02	55
22-01107-00	1	22-01744-00	47	22-02413-00	35, 55
22-01139-04	1	22-01777-00SV	13	22-02418-02	53
22-01140-01	1	22-01777-01SV	13	22-02420-00	53
22-01140-02	1	22-01777-03	13	22-04040-00	41
22-01140-04	1	22-01777-04	13	22-4031-00	13
22-01141-01	1	22-01778-00	49	22-4031-01	13
22-01551-00	46, 47	22-01883-00	47	22-4031-02	13
22-01556-00	15	22-01884-00	47	22-50007 Series	1
22-01556-01	13	22-01889-00	11	22-50088-00	27
22-01556-02	13	22-01891-00	47	22-50100-00	13
22-01556-04	15	22-01892-00	27	22-50127-00	35
22-01613-14	27, 35, 55	22-01892-01	27	22-50157-00	13
22-01613-15	27, 35	22-01906-00	47	22-01997-05	17
22-01613-34	27	22-01931-00	47	22-01997-10	17
22-01614-02	27	22-01932-00	47	24-00006-02	33
22-01614-03	27	22-02188-00	47	30-00407-01	13
22-01614-05	27	22-02232-00	47	30-00407-02SV	13
22-01621-03	15	22-02322-00	47	34-00373-05	1, 23
22-01621-23	13	22-02324-01	46, 49	34-00373-07	1, 21
22-01622-00	13	22-02324-02	47	34-00373-11	1
22-01622-01	13	22-02324-05	46	34-00373-51	1
22-01622-02	13	22-02336-02	1, 13	34-00373-53	1, 25
22-01660-00	35	22-02336-04	1	34-00373-54	25
22-01660-03	35, 55	22-02336-08	1, 13	34-00373-56	46
22-01660-04	35	22-02341-00	11	34-00373-59	1, 46
22-01660-08	35	22-02341-01	11	34-00373-65	1
22-01679-00	49	22-02368-00	11	34-00373-69	1
22-01679-01	49	22-02375-00	47	34-00373-71	1
22-01679-03	45	22-02378-00	46	34-00373-88	1
22-01713-02	15	22-02392-03	33	34-00616-06	27
22-01713-06	13	22-02393-01	33	34-00655-04	41
22-01713-12	44	22-02394-03	33	34-00655-10	27
22-01731-00	46	22-02396-02	15	34-00662-11	28, 29
22-01731-01	46	22-02396-03	15	34-00663-07	11
22-01734-01	49	22-02398-02	35	34-00663-09	7
22-01737-00	53	22-02398-03	35	34-00663-11	27
22-01737-01	53	22-02401-00	53	34-00665-09	7
22-01737-02	53	22-02412-00	35, 55	34-00666-09	31

PART NUMBER INDEX

PART NO.	PAGE NO.	PART NO.	PAGE NO.	PART NO.	PAGE NO.
34-00667-05	11	34-06174-04	41	40-01129-00	23
34-00667-09	23, 49	34-06179-00	39	42-00174-38	55
34-00667-11	41, 43, 46, 48	34-06179-04	39	42-00295-00	31
34-00667-13	41	34-06183-00	30, 31	42-00295-01	31
34-00795-09	7, 39	34-06185-01	29	42-00296-00	29
34-00795-17	27	34-06211-01	10	42-00296-01	28, 29
34-00848-10	11	34-06212-10	11	42-00327-00	28, 29
34-00928-01	9, 11	34-06221-00	49	42-00334-00	37
34-00928-02	9, 37	34-06223-00	11, 15	42-00384-01	21, 41, 56
34-00928-03	37	34-06223-01	15	42-00384-02	21, 41, 56
34-00928-09	31, 37	34-06224-01	10	42-00407-00	29
34-01142-01	9, 11	34-06231-01	9	42-00465-00	30
34-01167-01	7	34-06231-03	9	42-00470-00	49
34-01178-22	33	34-06231-04	9	42-00611-00	7
34-06053-00	7, 21, 25, 28, 29, 30, 39, 41, 43, 48	34-06231-05	9	42-00659-00	21
34-06053-02	41	34-06231-06	9	42-00660-00	21
34-06053-03	39, 43, 45, 46, 48	34-06231-07	9	42-01098-01	39
34-06053-04	31	34-06236-00	41, 56	42-50000-00	23
34-06053-05	7, 21, 25, 39, 43, 48, 49	34-06262-00	31	44-00300-01	7
34-06053-11	22, 23	34-06286-00	31	44-00300-02	7
34-06053-13	39	34-06287-00	31	44-00300-03	7
34-06053-18	30	34-06295-00	21	44-00343-00	9
34-06053-19	29	34-50015-00	9	44-00370-03	25
34-06053-20	41, 56	34-00663-11	18	44-00374-00	39
34-06060-03	41	34-00667-12	17	44-01043-05	1
34-06092-00	30, 31	34-00928-07	18, 19	44-01043-07	1
34-06107-00	7	34-01181-01	17	44-00374-00	19
34-06136-01	43	34-06051-36	18	48-00262-00	27
34-06139-03	9	34-06053-02	17	48-00350-01SV	41, 56
34-06154-00	28, 29	34-06053-03	18, 19	48-00377-00	31
34-06165-09	27	34-06169-00	19	54-00548-20	27
34-06169-00	7, 39	34-06179-00	19	54-00586-20	17
34-06174-03	41	34-66630-00	11	58-00065-27	25
		38-00557-00	27	58-00065-67	39
		38-00585-00	17	58-00065-70	39
		40-00520-01	25	58-00956-00	23
		40-00520-02	21	58-00969-00	21
		40-00542-00	21	58-01184-00	13, 15

PART NUMBER INDEX

PART NO.	PAGE NO.	PART NO.	PAGE NO.	PART NO.	PAGE NO.
58-04026-07	43, 46, 48	62-02723-04	51	66U1-2403	9, 37
58-04026-10	17	62-02723-06	51	66U1-2403-1	7
58-04026-17	48	62-02723-10	51	66U1-2552-185	28, 29
58-04026-22	45, 49	62-02735-00	13	66U1-2583	46
58-04026-26	21, 33	62-02738-04	13	66U1-2583-1	47
58-04026-33	22	62-02738-08	13	66U1-2603	45, 48
58-04026-59	25	62-02743-01	51	66U1-2763-5	23
58-04066-00	27	62-02743-10	51	66U1-3442-2	15
58-04101-00	7	62-02743-16	51	66U1-3632-20	21
58-04101-07	39	62-02743-18	51	66U1-3803	1, 23
58-04145-06	10	62-02743-19	51	66U1-3803-1	1
58-04251-00	29	62-02783-00	29	66U1-3882	43
58-04263-01	31	62-02785-00	50	66U1-3882-02	11
58-04276-00	26	62-02822-01	37	66U1-3882-3	21
58-04277-00SV	26	62-03957-01	9	66U1-5321-13	29
58-04278-00	26	62-10259-00	50	66U1-5321-3	27, 30, 33
58-04279-00	26	62-10381-00	31	66U1-5321-5	41
58-04316-00	43	62-10532-00	51	66U1-5321-6	11
58-04346-00	7	62-10532-02	51	66U1-5321-7	21, 22, 25, 26, 31, 39, 41, 43, 45, 46, 48
58-04366-00SV	7	62-10532-04	51	66U1-5321-8	7, 21,22, 23, 25,31, 33, 43,45, 48, 49
58-04435-00	41, 56	62-10537-00	31	66U1-5331-3	7
58-04436-00	23	62-10540-00	31	66U1-5361-11	43, 46, 48
58-04451-00	41, 56	62-10540-04	31	66U1-5361-25	21, 22, 25, 30, 33, 39, 43, 45, 48
58-04461-00	41, 56	62-10557-00	5	66U1-5361-47	41
58-04461-01	41, 56	62-10717-00	51	66U1-5362-2	29
58-04463-00	41	62-10754-00	50	66U1-5371-10	21, 33
58-04480-00	17	62-10766-00	51	66U1-5371-13	33
58-04481-00	17	62-10902-02	50	66U1-5371-6	21, 23, 25, 43, 45
58-04624-00	37	62-10902-03	50	66U1-5371-7	7, 11, 13, 21, 25, 26, 31, 33, 48
58-04668-00	9	62-10902-04	50	66U1-5381-1	46
58-04101-07	19	62-10984-00	31		
62-02444-01	50	62-11018-00	10		
62-02458-01	50	62-02785-00	17		
62-02530-01	50	62-11273-00	18		
62-02719-00	13	66CH-11172	21		
62-02721-07	50	66CH1-1002-33	31		
62-02723-00	51	66CH1-1172-46	11		
62-02723-02	51	66U1--2552-133	25		
62-02723-03	51	66U1--3803	25		

PART NUMBER INDEX

PART NO.	PAGE NO.	PART NO.	PAGE NO.	PART NO.	PAGE NO.
66U1-5732-1	25	68-13475-09	37	68-15148-00	22, 23
66U1-6651-4	11	68-13577-00	7	68-15148-01	22, 23
66U1-6782	47	68-13979-00	27	68-15149-00	43
66U1-6782-3	47	68-13983-00	27	68-15150-00	43, 44
66U1-6811-15	7	68-13984-00	27	68-12635-03	19
66U1-6811-8	7, 39	68-14038-04	37	68-12635-04	19
66U1-6835	11	68-14129-00	21	68-12635-05	18
66U1-6912-16	33	68-14129-01	21	68-12635-06	18
66U1-7352	43, 44	68-14142-00	21	68-12635-21	19
66U1-7352-3	44	68-14142-01	21	68-12635-22	18
66U1-7842-13	11	68-14143-00	43	69NP20-1031	25
66U1-7982-2	37	68-14268-00	25	69NT35-1287-1	31
66U1-8075	37	68-14268-01	25	69NT35-1417	31
66U1-8115	29	68-14269-01	25	69NT35-2257	37
66U1-8662	5	68-14269-02	25	69NT35-2287	9
66U1-9212-1	15	68-14278-00	25	69NT35-2692	13, 22, 23, 37
66U1-9752	10, 11	68-14278-01	25	69NT35-2692-1	27, 30, 33, 39, 43
66U1-9782	46, 47	68-14373-00	37	69NT35-3867	50
66U1-9782-1	47	68-14413-00	25	69NT35-3907	50
66U1-5361	17	68-14413-01	25	69NT35-3987	4
66U1-5361-25	18	68-14456-00	43, 44	69NT35-3997-1	4
66U1-6811-12	19	68-14456-01	44, 46	69NT35-4047	30
66U1-6811-8	19	68-14706-01	41, 43	69NT35-5022-5	39
66U2-1132-1	23	68-14796-00	11	69NT35-5022-6	7
66U2-1142	23	68-14796-03	11	69NT35-5352-1	39
66U2-1152	23	68-14955-00	31	69NT35-5992	45, 48
66U2-1531	49	68-14989-00	25	69NT35-6118	50
68-12417-00	4	68-15001-00	25	69NT35-6272-1	9
68-12434-02	55	68-15001-01	25	69NT35-6278	11
68-12553-00	55	68-15013-00	37	69NT35-6412	46
68-12658-04	39	68-15014-00	37	69NT35-6412-2	46
68-12658-20	39	68-15105-00	43	69NT35-6522	33
68-13181-00	33	68-15105-01	44	69NT35-6532	33
68-13201-01	17	68-15106-00	43, 44	69NT35-7012	31
68-13294-00	41	68-15106-01	44	69NT35-8113	4
68-13427-00SV	10	68-15109-00	43	69NT35-8348	31
68-13475-00	37	68-15109-01	44	69NT35-8382	45, 49
68-13475-01	37	68-15118-00	43, 44		
68-13475-08	37	68-15118-01	44		

PART NUMBER INDEX

PART NO.	PAGE NO.	PART NO.	PAGE NO.	PART NO.	PAGE NO.
69NT35-8548	4	76-00670-01	49	79-66635-03	19
69NT35-8703	17	76-00670-02	49	79-66635-04	19
69NT35-9228	31	76-00670-03	49	79-66635-05	19
69NT35-9238	31	76-00670-04	49	79-66635-06	19
69NT35-2692-1	18, 19	76-00675-01	33	79-66635-07	19
69NT35-3452	17	76-00676-00	35	79-66669-00	10
69NT35-3452-1	17	76-00701-05	39	81-01539-20	25
69NT35-3452-2	17	76-00701-06SV	39	81-01855-22SV	17
69NT35-3452-3	17	76-00701-10	39	81-01907-01	21
69NT35-6112	17	76-00701-11	39	81-01980-01	21
69NT40-222	11, 55	76-00724-00SV	9	81-01996-01	21
69NT40-976-3	30	76-00734-00	23	86-04405-00	41
69NT41-192	55	76-00746-05	37	86-04406-00	41
69NT41-782	31	76-50058-00	53	86-04637-00	18, 19
69NT41-852-1	30	76-50059-00	53	86-04637-01	18, 19
69NT41-982-3	10	76-50084-00SV	9	86-04637-02	18, 19
69NT41-992	35	76-50116-00	31		
69NT42-688-10	7	76-50116-01	31	A	
69NT42-688-7	7	76-50116-02	31	AA06JA170	48
69NT42-954-4	23	76-50116-03	31	AU11JR171	33, 48
69NT43-124-5	9	76-50116-04	31		
69NT43-125-1	9	76-50136-00	31	D	
69NT43-148-4	17	76-50149-00	13	DE40BA-203	25
69NT43-175	35	77-01191-00	43	DE40BA3-03	25
69NT43-176	35, 55	77-01191-02	43		
69NT43-295	27	77-01191-04	43	E	
69NT43-307	30	77-01191-05	44	EC39DM070	44
69NT43-374	48	77-01191-06	44		
69NT43-464	37	79-01694-00	29	K	
69NT43-470	49	79-01697-06SV	28	KA-66FA-060	21
69NT43-470-1	49	79-01697-14SV	29	KA66FA138	33
69NT43-470-2	49	79-01785-01	22		
74-00201-01	29	79-01902-00	29	P	
74-00201-02	29	79-01925-00	31	PF-01-24	43
74-50137-00	1	79-01934-00	31	PF-20-21	43
74-50137-01	1	79-01937-02	19		
76-00397-10	1	79-66635-00	18		
76-00397-11	1	79-66635-01	18		
76-00667-05	49	79-66635-02	18		



A member of the United Technologies Corporation family. Stock symbol UTX
©2009 Carrier Corporation • Printed in U. S. A. 0609



Carrier

A United Technologies Company

Carrier Transicold Division,
Carrier Corporation
Container Products Group
P.O. Box 4805
Syracuse, N.Y. 13221 U.S.A

www.carrier.transicold.com